

Rolife

BOOK NOOK & WONDERLAND

• TGB07 BOOKSTORE

- EN Assembly instruction
- IT Istruzioni per il montaggio
- DE Anleitung zur montage
- ES Instrucciones de montaje
- FR Instructions de montage

Designed by **ROBOTIME**
www.robotime.com
MADE IN CHINA

49.1TGB07.100.B

The picture is for reference only.



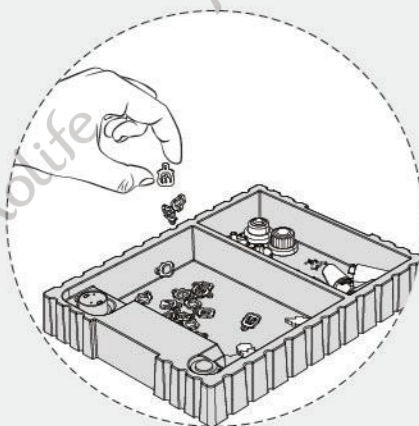

Put small parts into the box to prevent loss.
Legen Sie kleine Teile zurück in die Schachtel, damit sie nicht verloren gehen.
Remettez les petites pièces dans la boîte pour éviter de les perdre.
Mettete i pezzi piccoli nella scatola per evitare di perderli.
Coloque las piezas pequeñas en la caja para evitar pérdidas.

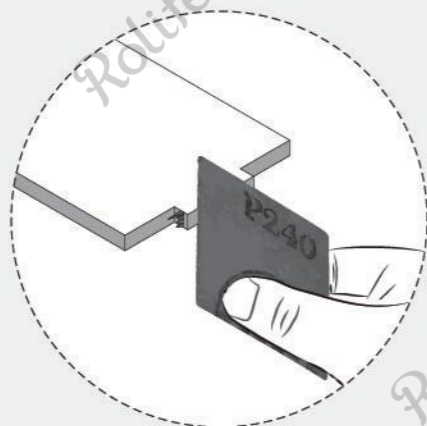

Polish the edges with sandpaper if there are burrs on pieces or it's hard to insert.
Polieren Sie die Kanten mit Schleifpapier, wenn die Teile Grate aufweisen oder sich nur schwer einfügen lassen.
Polissez les bords avec du papier de verre si les pièces présentent des bavures ou si elles sont difficiles à insérer.
Se i pezzi presentano imperfezioni o sono difficili da inserire, levigare i bordi con la carta vetrata.
Púja los bordes con papel de lija si hay rebabas en las piezas o es difícil insertarlas.

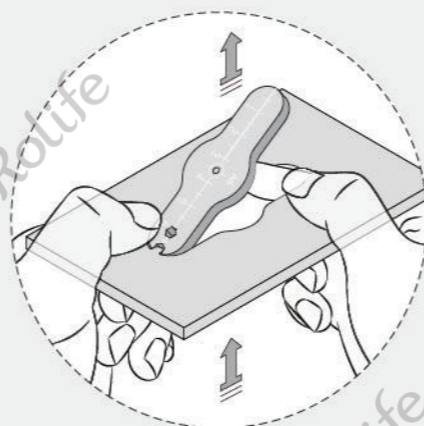

Remove the part by pressing its back to reduce burrs.
Drücken Sie das Teil von hinten heraus, um Splitter zu vermeiden.
Poussez la pièce par l'arrière pour éviter les éclats.
Rimuovere il pezzo premendo sulla parte posteriore in modo da evitare le sbavature.
Retire la pieza presionando su parte posterior para reducir las rebabas.

⚠ WARNING

- The product requires 2 "AAA/LR03/AM4 1.5V" batteries (batteries for self-preparation).
- Screw the fastener on the rear cover of the battery box using a screwdriver to remove or insert the batteries.
- Non-rechargeable batteries are not to be recharged.
- Rechargeable batteries are only to be charged under adult supervision.
- Rechargeable batteries are to be removed from the toy before being charged.
- Different types of batteries, new and old batteries cannot be mixed in use.
- Batteries are to be inserted with the correct polarity (+ and -).
- Remove the exhausted battery in time.
- The power supply terminal cannot be short circuited.
- The wire in the package cannot be connected with the plug.
- Connect the toy to the battery that we recommend rather than the device with more than 2 batteries.
- Check each part before assembly. If the part is damaged, fix it well before assembly.
- Please keep the product away from fire or any place that may cause damage.
- The package includes important information and please keep it well for future reference.

⚠ ATTENTION

- The product is for people who are over 14 years old. Children should assemble under the guidance of adults.
- The product contains small parts and electronic components. Adults should guide and supervise children in the correct use of the product to prevent ingestion or choking.
- Some auxiliary tools are required to assemble our products. Please choose reasonably to avoid injury.
- Please read the instruction carefully to assure that all parts are intact before assembling.
- Please cut and assemble these delicate parts carefully. Some parts need to be assembled with adhesive tape to ensure all parts are sticky firmly.
- Please install the electronic components correctly and test whether the circuit is normal after completion.
- Please don't clean this product with chemical cleaners: alcohol, ammonia water, glass cleaner, etc.
- Please clean the product with a clean soft cloth, and sand the board burr lightly with sandpaper.
- Due to customs policy in international shipping, the batteries, glue, or pigment may not be included. Please prepare them yourself.

● Q&A

- Q1: What if there are burrs on the edges of parts or it's hard to insert?
A1: Polish the joints with sandpaper to enhance assembling accuracy, and polish the burrs to ensure safety.
- Q2: What if the parts are loose after disassembling and assembling?
A2: Apply a dab of glue to the joints.
- Q3: What if the light doesn't work after turning on the switch?
A3: 1. Check if the batteries are inserted and with the correct polarity.
2. Check if the switch of the battery box is on.
3. Check if the light parts and the touch board are completely welded and do not have breakage.
4. Check if the wires are connected to the same color ones.
5. Check if the touch board aligns with the wooden board and there is no gap between them.

● Icon Illustration

- 1 Step 1 Printed side Use the double-sided tape
- 2 Step 2 Blank side Use the invisible tape
- Perspective changed Flip to assemble
- Remove protective film Complete 2 same parts
- Special attention in assembly

⚠ ACHTUNG

- Das Produkt benötigt 2 "AAA/LR03/AM4 1.5V"-Batterien. (Batterien zur Selbstvorbereitung).
- Bevor Sie die Batterien laden oder entfernen, lösen Sie bitte zuerst die Schrauben auf dem Batteriefachdeckel mit dem Schraubendreher.
- Nicht wiederaufladbare Batterien dürfen nicht aufgeladen werden.
- Wiederaufladbare Batterien dürfen nur unter Aufsicht von Erwachsenen aufgeladen werden.
- Wiederaufladbare Batterien müssen vor dem Aufladen aus dem Spielzeug entfernt werden.
- Verschiedene Arten von Batterien oder neue und gebrauchte Batterien dürfen nicht gemischt werden.
- Batterien müssen mit der richtigen Polarität (+ und -) eingesetzt werden.
- Entfernen Sie rechtzeitig die erschöpfte Batterie.
- Der Stromversorgungsanschluss darf nicht kurzgeschlossen werden.
- Schließen Sie das Kabel nicht an eine Netzsteckdose an.
- Das Produkt darf nicht mit mehr als der empfohlenen Anzahl von Stromquellen verbunden werden.
- Überprüfen Sie jedes Teil vor dem Zusammenbau. Wenn das Teil beschädigt ist, reparieren Sie es vor dem Zusammenbau gut.
- Bitte bewahren Sie das Produkt fern von brennbaren Stoffen und feuchter Umgebung auf, um Beschädigungen zu vermeiden.
- Die Anleitung muss aufbewahrt werden, da sie wichtige Informationen enthält.

⚠ BEMERKUNG

- Das Produkt ist für Menschen, die über 14 Jahre alt sind. Kinder sollten sich unter Anleitung von Erwachsenen versammeln.
- Dieses Produkt enthält kleine Teile und elektronische Komponenten. Erwachsene sollten Kinder bei der korrekten Verwendung des Produkts anleiten und beaufsichtigen, um ein Verschlucken oder Erstickung zu vermeiden.
- Für den Zusammenbau unserer Produkte sind einige Hilfswerkzeuge erforderlich. Bitte wählen Sie diese vernünftig aus, um Verletzungen zu vermeiden.
- Bitte lesen Sie die Anleitung sorgfältig durch, um sicherzustellen, dass alle Teile vor dem Zusammenbau intakt sind.
- Bitte schneiden Sie diese empfindlichen Teile sorgfältig zu und montieren Sie sie. Einige Teile müssen mit Klebeband zusammengefügt werden, um sicherzustellen, dass alle Teile fest haften.
- Testen Sie, ob die Schaltkreise nach der Installation ordnungsgemäß funktionieren.
- Bitte reinigen Sie dieses Produkt nicht mit chemischen Reinigungsmitteln wie: Alkohol, Ammoniakwasser, Glasreiniger usw.
- Bitte reinigen Sie das Produkt mit einem sauberen, weichen Tuch und schleifen Sie den Grat der Holzplatte leicht mit Schleifpapier ab.
- Aufgrund der Zollbestimmungen für den internationalen Versand sind die Batterien, der Klebstoff oder die Pigmente möglicherweise nicht im Lieferumfang enthalten. Bitte bereiten Sie sie selbst vor.

● F&A

F1: Was tun, wenn sich an den Kanten der Teile Grate befinden oder sie sich nur schwer einfügen lassen?

A1: Polieren Sie die Verbindungsstellen mit Schleifpapier, um die Genauigkeit beim Zusammenbau zu verbessern, und polieren Sie die Grate, um die Sicherheit zu gewährleisten.

F2: Was ist, wenn sich die Teile nach dem Zerlegen und Zusammensetzen lösen?

A2: Tragen Sie einen Klecks Kleber auf die Verbindungen auf.

F3: Was ist, wenn das Licht nach dem Einschalten des Schalters nicht mehr funktioniert?

- A3: 1. Prüfen Sie, ob die Batterien eingelegt sind und die richtige Polarität haben.
2. Prüfen Sie, ob der Schalter des Batteriekastens eingeschaltet ist.
3. Prüfen Sie, ob die Lichtteile und das Touchboard vollständig angeschlossen sind und keine Brüche aufweisen.
4. Prüfen Sie, ob die Drähte mit den gleichfarbigen Drähten verbunden sind.
5. Prüfen Sie, ob das Touch Board mit dem Holzbrett übereinstimmt und es keine Lücke zwischen ihnen gibt.

● Erklärung der Symbole

- | | | |
|-----------------------------------------------------------------------------------------------------------------------------------|----------------------------------------------------------------------------------------------------------|-------------------------------------------------------------------------------------------------------------------------------|
|  Schritt 1 |  Bedruckte Seite |  Verwenden Sie das doppelseitige Klebeband |
|  Schritt 2 |  Seite ohne Musterung |  Verwenden Sie das unsichtbare Klebeband |
|  Blickwinkelwechsel | |  Die Baugruppe umdrehen |
|  Schutzfolie entfernen | |  Vervollständigen Sie 2 gleiche Teile |
|  Achten Sie bei der Montage besonders darauf | | |

DE

⚠ AVERTISSEMENT

- Le produit nécessite 2 piles "AAA/LR03/AM4 1.5V" (piles pour auto-préparation).
- Avant de charger ou de retirer les piles, desserrez d'abord les vis du couvercle du compartiment à piles avec le tournevis.
- Les piles non rechargeables ne doivent pas être rechargées.
- Les piles rechargeables doivent être chargées uniquement sous la surveillance d'un adulte.
- Les piles rechargeables doivent être retirées du jouet avant d'être chargées.
- Les différents types de piles ou les piles neuves et usagées ne doivent pas être mélangés.
- Insérez les piles avec la polarité correcte (+ et -).
- Retirez la pile épuisée à temps.
- La borne d'alimentation ne doit pas être court-circuitée.
- Ne connectez pas le fil à une prise secteur.
- Le produit ne doit pas être connecté à plus du nombre recommandé de sources d'alimentation.
- Vérifiez chaque pièce avant l'assemblage. Si la pièce est endommagée, réparez-la correctement avant l'assemblage.
- Veuillez éloigner le produit des substances inflammables et des environnements humides pour éviter les dommages.
- Les instructions doivent être conservées car elles contiennent des informations importantes.

⚠ ATTENTION

- Le produit est destiné aux personnes de plus de 14 ans. Les enfants devraient être rassemblés sous la direction d'un adulte.
- Ce produit contient de petites pièces et des composants électroniques. Les adultes doivent guider et surveiller les enfants lors de l'utilisation correcte du produit afin d'éviter tout risque d'ingestion ou de suffocation.
- Certains outils auxiliaires sont nécessaires pour assembler nos produits. Veuillez les choisir raisonnablement afin d'éviter toute blessure.
- Veuillez lire attentivement les instructions afin de vous assurer que toutes les pièces sont intactes avant de procéder à l'assemblage.
- Veuillez couper et assembler ces pièces délicates avec soin. Certaines pièces doivent être assemblées avec du ruban adhésif pour s'assurer que toutes les pièces sont collantes fermement.
- Testez si les circuits fonctionnent correctement après l'installation.
- Veuillez ne pas nettoyer ce produit avec des détergents chimiques tels que : alcool, eau ammoniacale, nettoyant pour vitres, etc.
- Veuillez nettoyer le produit avec un chiffon doux propre et poncer légèrement les bords de la plaque à l'aide de papier de verre.
- En raison des réglementations douanières pour l'expédition internationale, il se peut que les piles, la colle ou les pigments ne soient pas inclus dans la livraison. Veuillez les préparer vous-même.

FR

● Q&R

Q1 : Que faire s'il y a des bavures sur les bords des pièces ou si elles sont difficiles à insérer ?

R1 : Polir les jonctions avec du papier de verre pour améliorer la précision lors de l'assemblage et polir les bavures pour assurer la sécurité.

Q2 : Que faire si les pièces se détachent après le démontage et l'assemblage ?

R2 : Appliquez un peu de colle sur les assemblages.

Q3 : Que faire si la lumière ne fonctionne plus après avoir allumé l'interrupteur ?

R3 : 1. Vérifier si les piles sont installées et si elles ont la bonne polarité.

2. Vérifier si l'interrupteur du boîtier de batteries est allumé.

3. Vérifiez si les parties lumineuses et la carte tactile sont entièrement connectées et ne présentent pas de cassures.

4. Vérifiez que les fils sont bien connectés aux fils de même couleur.

5. Vérifiez que la carte tactile correspond à la planche de bois et qu'il n'y a pas d'espace entre elles.

● Explication des symboles

- | | | |
|------------------------------------------------------------------------------------------------------------------------------|--------------------------------------------------------------------------------------------------|---------------------------------------------------------------------------------------------------------------------------|
|  Étape 1 |  Côté imprimé |  Utiliser le ruban adhésif double face |
|  Étape 2 |  Côté vierge |  Utiliser le ruban adhésif invisible |
|  Changement de perspective | |  Pièces retournées |
|  Retirez le film protecteur | |  Complétez 2 pièces identiques |
|  Attention particulière lors du montage | | |

⚠ AVVERTENZA

- Il prodotto richiede 2 batterie "AAA/LR03/AM4 1.5V" (batterie per auto-preparazione).
- Prima di caricare o rimuovere le batterie, allentare le viti sul coperchio del vano batterie con il cacciavite.
- Le batterie non ricaricabili non devono essere ricaricate.
- Le batterie ricaricabili devono essere caricate solo sotto la supervisione di un adulto.
- Le batterie ricaricabili devono essere rimosse dal giocattolo prima di essere caricate.
- Non mescolare tipi diversi di batterie o batterie nuove e usate.
- Inserire le batterie con la corretta polarità (+ e -).
- Rimuovere la batteria esausta in tempo.
- Il terminale dell'alimentazione non può essere cortocircuitato.
- Non collegare il filo a una presa di corrente.
- Il prodotto non deve essere collegato a un numero di alimentatori superiore a quello consigliato.
- Controllare ogni parte prima del montaggio. Se la parte è danneggiata, ripararla bene prima del montaggio.
- Mantenere il prodotto lontano da sostanze infiammabili e ambienti umidi per evitare danni.
- Le istruzioni devono essere conservate poiché contengono informazioni importanti.

⚠ NOTA

- Il prodotto è per le persone che hanno più di 14 anni. I bambini dovrebbero riunirsi sotto la guida degli adulti.
- Questo prodotto contiene piccoli pezzi e componenti elettrici. Gli adulti devono controllare e supervisionare i bambini nell'uso corretto del prodotto per evitare il rischio di ingestione o di soffocamento.
- Per l'assemblaggio dei nostri prodotti sono necessari alcuni utensili ausiliari. Si raccomanda di sceglierli in modo appropriato al fine di evitare infortuni.
- Leggere attentamente le istruzioni per assicurarsi che tutte le parti siano intatte prima di assemblarle.
- Si prega di tagliare e assemblare queste parti delicate con cura. Alcune parti devono essere assemblate con nastro adesivo per garantire che tutte le parti siano saldamente appiccicose.
- Assemblare correttamente i componenti elettrici. Verificare il corretto funzionamento dei circuiti dopo l'installazione.
- Non pulire il prodotto con detergenti chimici: alcool, ammoniaca, detergenti per vetri, ecc.
- Pulire il prodotto con un panno morbido e pulito, levigare le imperfezioni del bordo delicatamente con carta vetrata.
- A causa della politica doganale delle spedizioni internazionali, le batterie, la colla o il colore potrebbero non essere inclusi. Si prega di prepararli autonomamente.

IT

● Domande frequenti

DOMANDA 1: Cosa succede se ci sono imperfezioni ai bordi dei pezzi o se è difficile inserirli?

RISPOSTA 1: Limare le giunzioni con la carta vetrata per migliorare la precisione dell'assemblaggio e lucidare le sbavature per garantire una maggiore sicurezza.

DOMANDA 2: Cosa succede se le parti si allentano dopo lo smontaggio e l'assemblaggio?

RISPOSTA 2: Applicare un gocciolo di colla sulle giunzioni.

DOMANDA 3: Cosa succede se la luce non funziona dopo aver acceso l'interruttore?

- RISPOSTA 3: 1. Verificare che le batterie siano inseriti con la corretta polarità.
2. Verificare che l'interruttore della scatola della batteria sia acceso.
3. Verificare che le parti luminose e la scheda tattile siano correttamente collegate e non siano danneggiate.
4. Verificare che i fili dello stesso colore siano collegati correttamente tra loro.
5. Verificare che la scheda tattile sia allineata con il pannello di legno e che non vi sia alcuno spazio tra di esse.

● Legenda delle icone

- | | | |
|-----------------------------------------------------------------------------------------------------------------------------------------------|-----------------------------------------------------------------------------------------------------------------|----------------------------------------------------------------------------------------------------------------------|
|  Punto 1 |  Lato stampato |  Utilizzare il nastro biadesivo |
|  Punto 2 |  Facciata senza figure |  Utilizzare il nastro trasparente |
|  L'angolo di visualizzazione cambia |  Capovolge l'assemblea | |
|  Rimuovi la pellicola protettiva |  Completare 2 pezzi uguali | |
|  Prestare un'attenzione particolare durante il montaggio | | |

⚠ ADVERTENCIA

- El producto requiere 2 pilas "AAA/LR03/AM4 1.5V" (pilas para auto-preparación).
- Antes de cargar o quitar las pilas, afloje los tornillos de la tapa del compartimento de pilas con el destornillador primero.
- No se deben recargar las pilas no recargables.
- Las pilas recargables solo deben cargarse bajo supervisión de un adulto.
- Las pilas recargables deben ser retiradas del juguete antes de ser cargadas.
- No se deben mezclar diferentes tipos de pilas o pilas nuevas y usadas.
- Las pilas deben insertarse con la polaridad correcta (+ y -).
- Retire la pila agotada a tiempo.
- El terminal de suministro de energía no puede estar en cortocircuito.
- No conecte el cable a una toma de corriente principal.
- El producto no debe conectarse a más del número recomendado de fuentes de alimentación.
- Verifique cada parte antes del montaje. Si la parte está dañada, repárela bien antes del montaje.
- Mantenga el producto alejado de sustancias inflamables y entornos húmedos para evitar daños.
- Las instrucciones deben conservarse, ya que contienen información importante.

⚠ ATENCIÓN

- Este producto está disponible para personas mayores de 14 años. Los niños deben reunirse bajo la Guía de adultos.
- Este producto contiene piezas pequeñas y componentes electrónicos. Los adultos deben orientar y supervisar a los niños en el uso correcto del producto para evitar su ingestión o asfixia.
- Se requieren algunas herramientas auxiliares para ensamblar nuestros productos. Elija razonablemente para evitar lesiones.
- Lea las instrucciones cuidadosamente para asegurarse de que todas las piezas estén intactas antes de ensamblarlas.
- Por favor, corte y ensamble estas piezas delicadas cuidadosamente. Algunas piezas deben ensamblarse con cinta adhesiva para garantizar que todas las partes estén pegajosas firmemente.
- Monte correctamente los componentes electrónicos. Pruebe si los circuitos funcionan correctamente después de la instalación.
- Por favor, no limpie este producto con limpiadores químicos: alcohol, agua con amoníaco, limpiavidrios, etc.
- Por favor, limpie el producto con un paño limpio y suave, lije la placa ligeramente con papel de lija.
- Debido a políticas aduaneras en despachos internacionales, las baterías, el pegante o el pigmento pueden no estar incluidos. Por favor, prepárelos usted mismo.

ES

● Preguntas frecuentes

P1: ¿Qué pasa si hay rebabas en los bordes de las piezas o se dificulta la inserción?

R1: Pula las uniones con papel de lija para mejorar la precisión del montaje y pula las rebabas para garantizar la seguridad.











P2: ¿Que pasa si las piezas se aflojan después de desmontar y montar?

R2: Aplique una gota de pegante a las uniones.

P3: ¿Qué pasa si la luz no funciona después de encender el interruptor?

- R3: 1. Compruebe si las baterías están colocadas y con la polaridad correcta.
2. Compruebe si el interruptor de la caja de baterías está encendido.
3. Verifique si las piezas de la luz y la placa táctil están completamente soldadas y no tienen roturas.
4. Compruebe si los cables están conectados a los del mismo color.
5. Compruebe si la placa táctil se alinea con la placa de madera y si no hay espacio entre ellas.

● Ilustración del icono

- | | | |
|-----------------------------------------------------------------------------------------------------------------------|-----------------------------------------------------------------------------------------------------------------------|---------------------------------------------------------------------------------------------------------------|
|  Paso 1 |  Lado impreso |  Use la cinta de doble faz |
|  Paso 2 |  Cara en blanco |  Use la cinta invisible |
|  Cambio de perspectiva |  Componente de volteo | |
|  Retira la película protectora |  Completar 2 componentes iguales | |
|  Atención especial en el montaje | | |

1

Invisible tape in Bag **TGB07 4-2**
 Unsichtbares Klebeband im Beutel **TGB07 4-2**
 Ruban adhésif invisible dans le sachet **TGB07 4-2**
 Nastro trasparente nel sacchetto **TGB07 4-2**
 Cinta invisible en la Bolsa **TGB07 4-2**

Double-sided tape in the box
 Doppelseitiges Klebeband in der Schachtel
 Ruban adhésif double face dans la boîte
 Nastro biadesivo nella scatola
 Cinta de doble faz en la caja

Blank side
 Seite ohne Musterung
 Côté vierge
 Facciata senza figure
 Cara en blanco

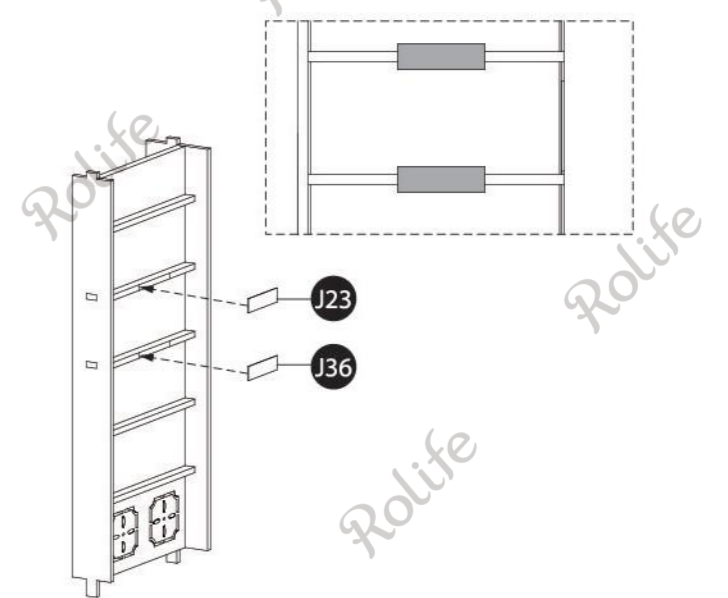
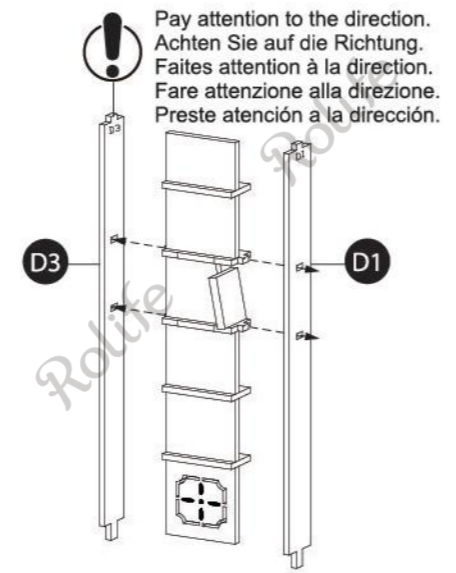
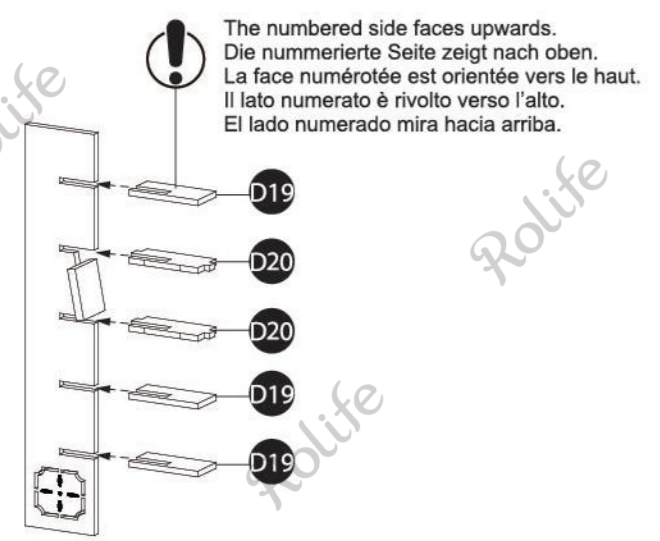
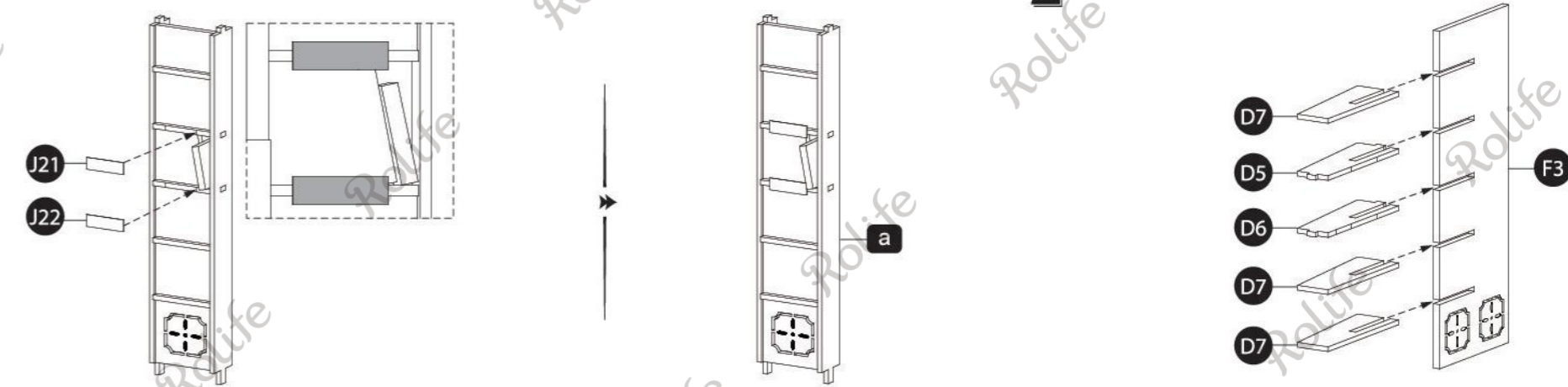
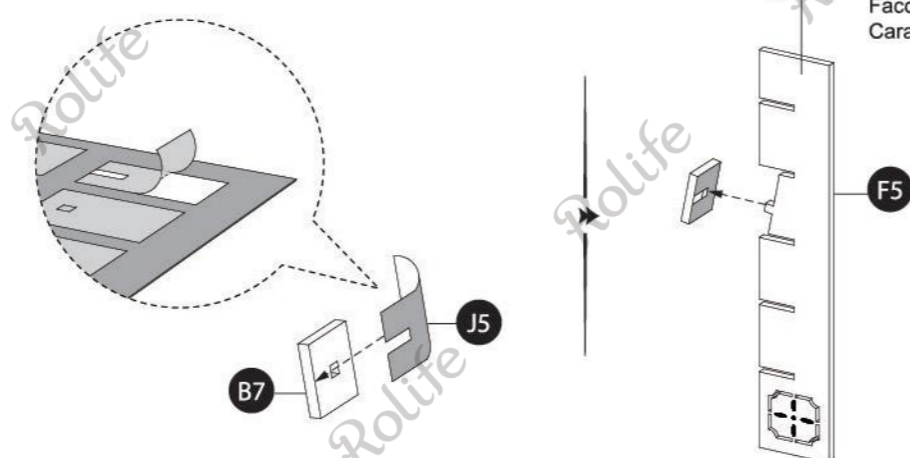

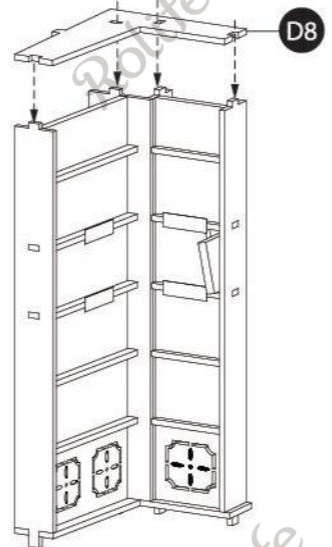
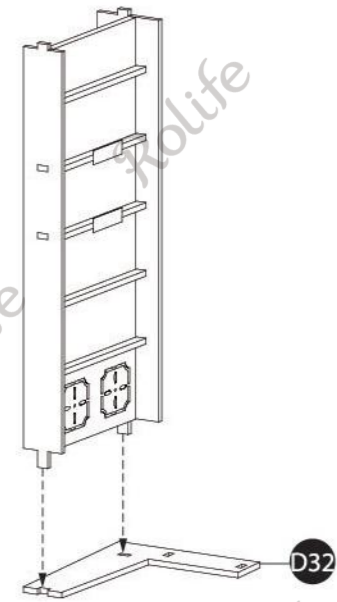

Use the invisible tape
Verwenden Sie das unsichtbare Klebeband
Utiliser le ruban adhésif invisible
Utilizzare il nastro trasparente
Use la cinta invisible

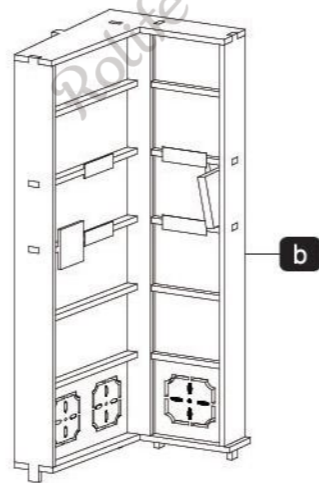
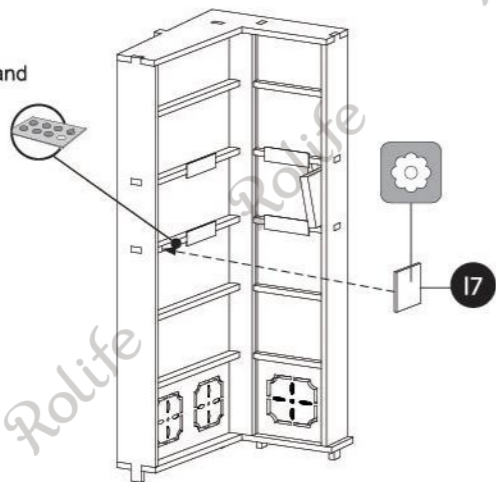

3

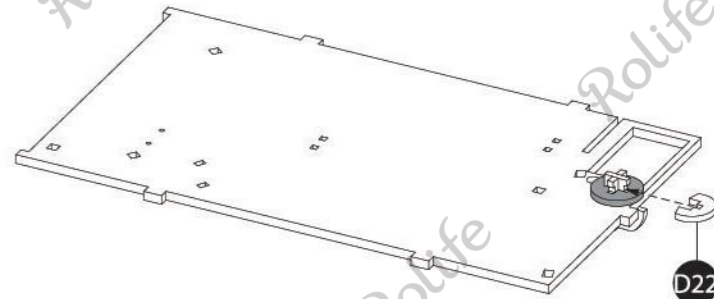
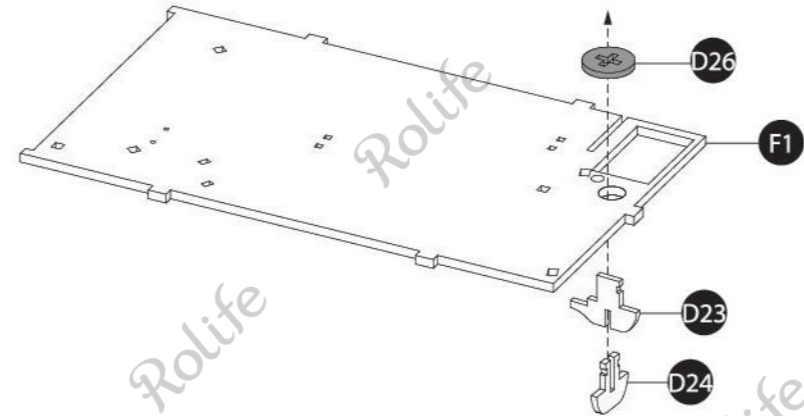

4

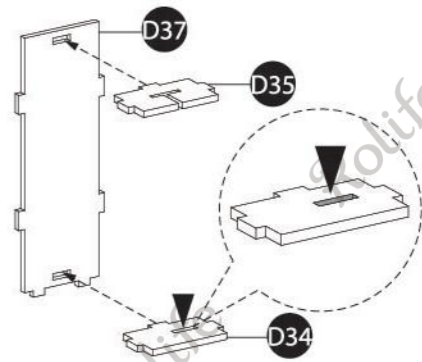
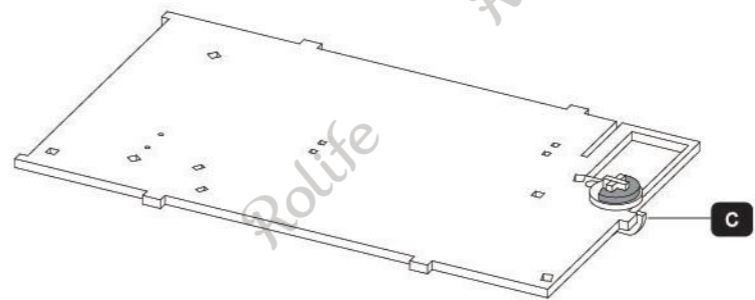

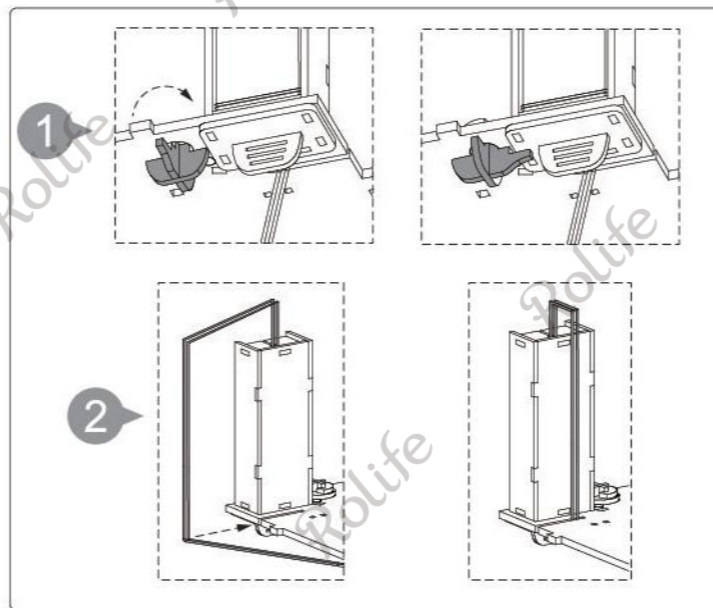
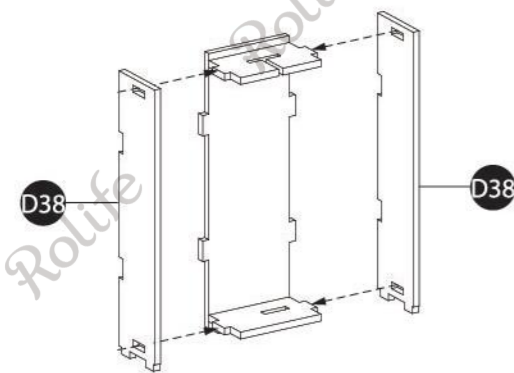

Step 1
Schritt 1
Étape 1
Punto 1
Paso 1

1

Rotate it to fix the battery box.
Drehen Sie es, um den Batteriekasten zu befestigen.
Tournez-le pour fixer la boîte à piles.
Ruotarlo per fissare la scatola della batteria.
Gírelo para fijar la caja de baterías.

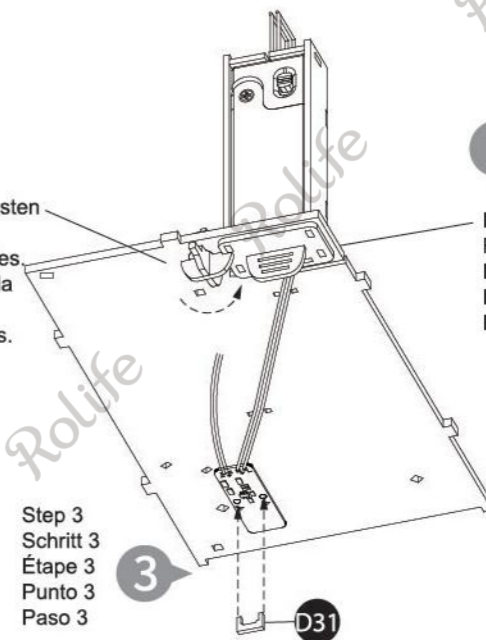

Step 2
Schritt 2
Étape 2
Punto 2
Paso 2

2

Insert the wire into the groove as shown.
Führen Sie den Draht wie abgebildet in die Rille ein.
Insérez le fil dans la rainure comme illustré.
Inserire i fili nella scanalatura come illustrato.
Inserte el cable en la ranura como se indica.

Step 3
Schritt 3
Étape 3
Punto 3
Paso 3

! D31 has spare parts.
D31 hat Ersatzteile.
Le D31 a des pièces de rechange.
D31 dispone di pezzi di ricambio.
D31 tiene repuestos.

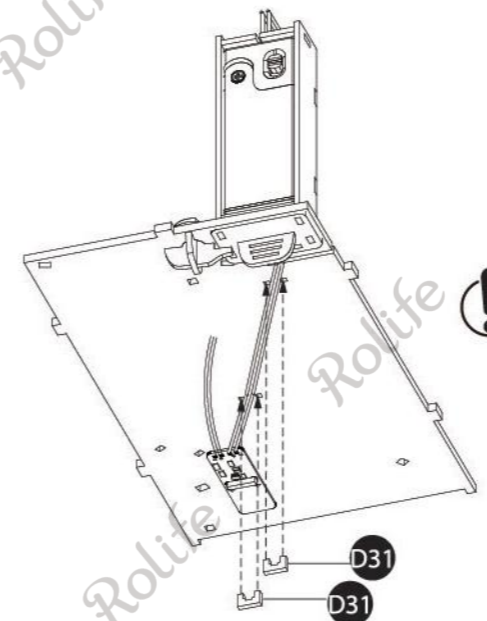
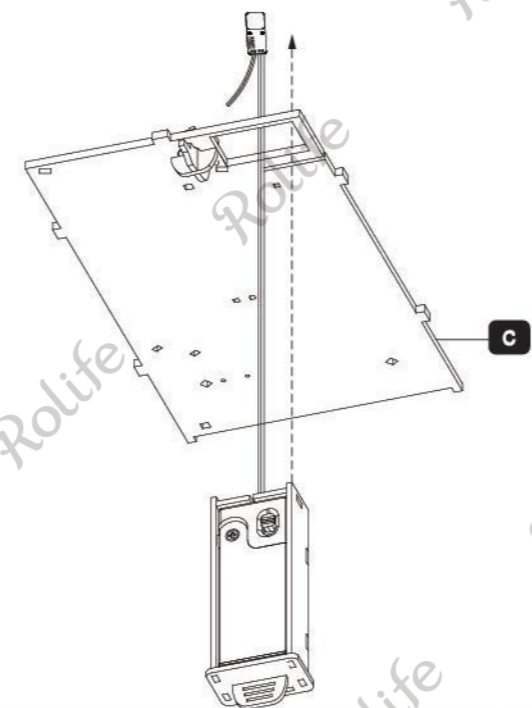
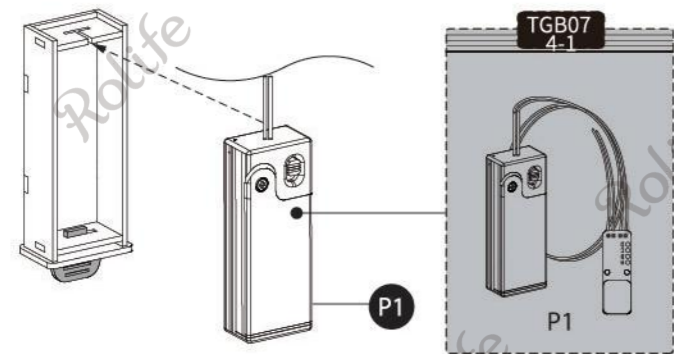

! D31 has spare parts.
D31 hat Ersatzteile.
Le D31 a des pièces de rechange.
D31 dispone di pezzi di ricambio.
D31 tiene repuestos.

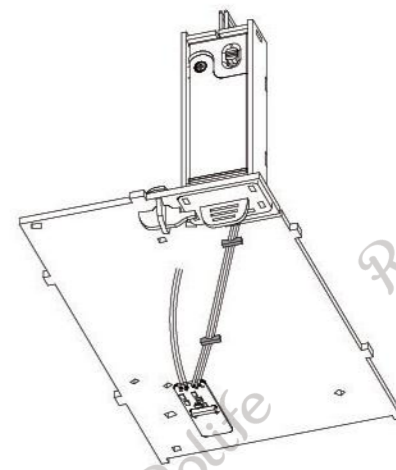

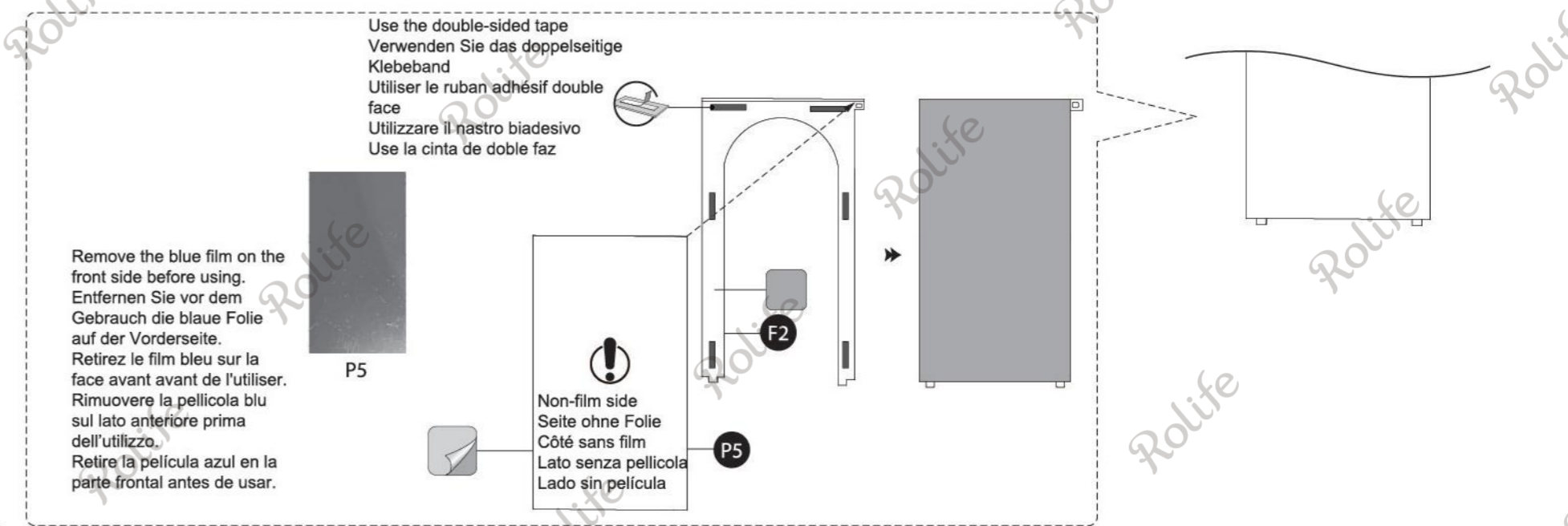
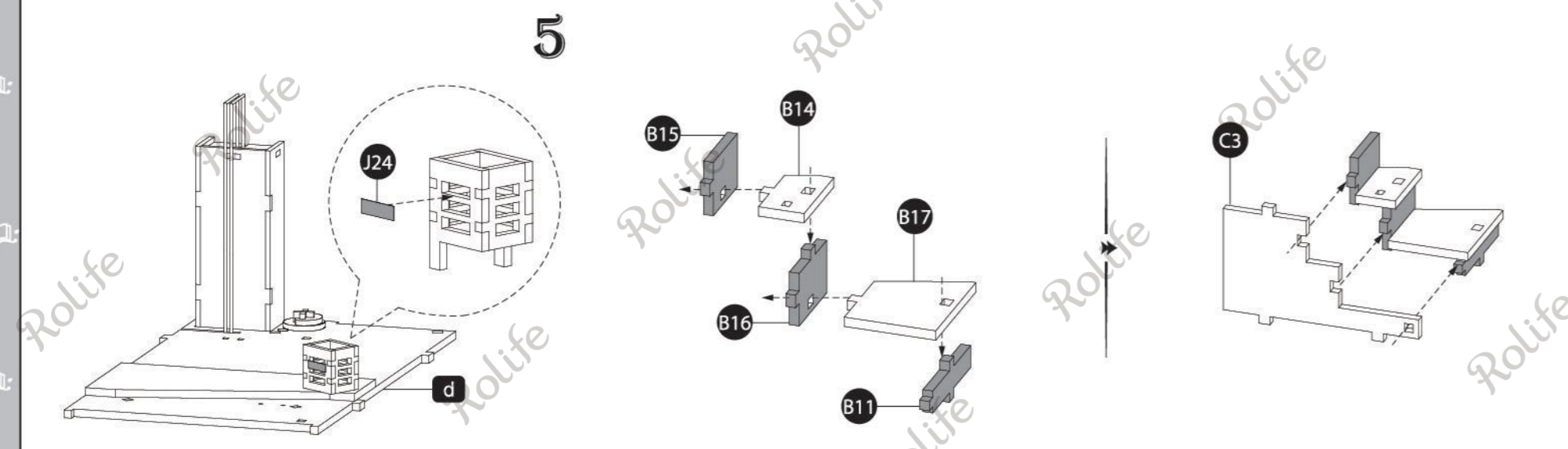
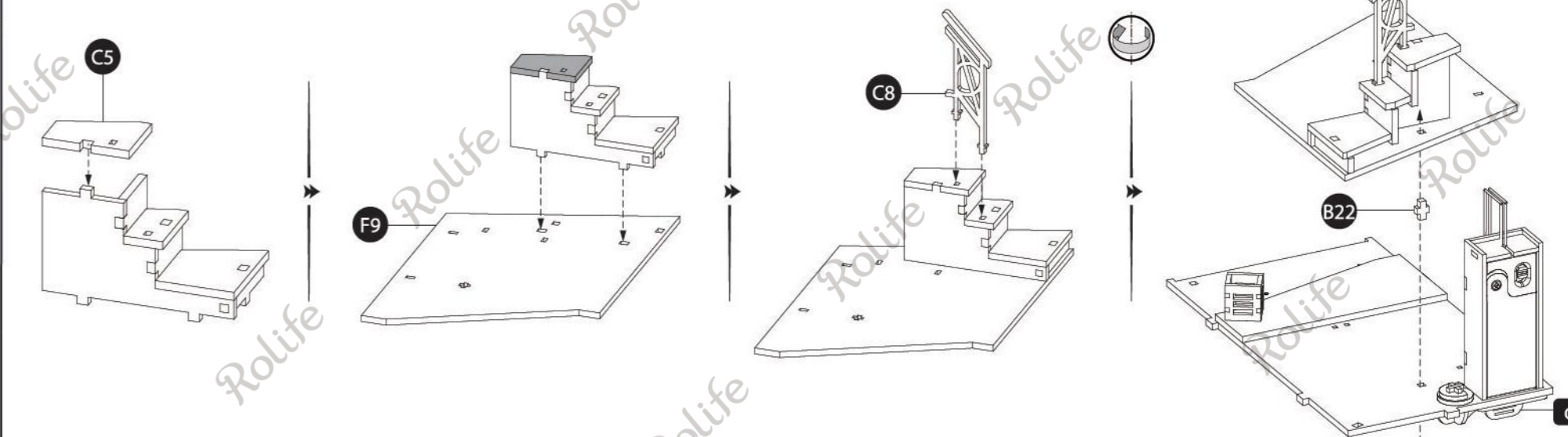
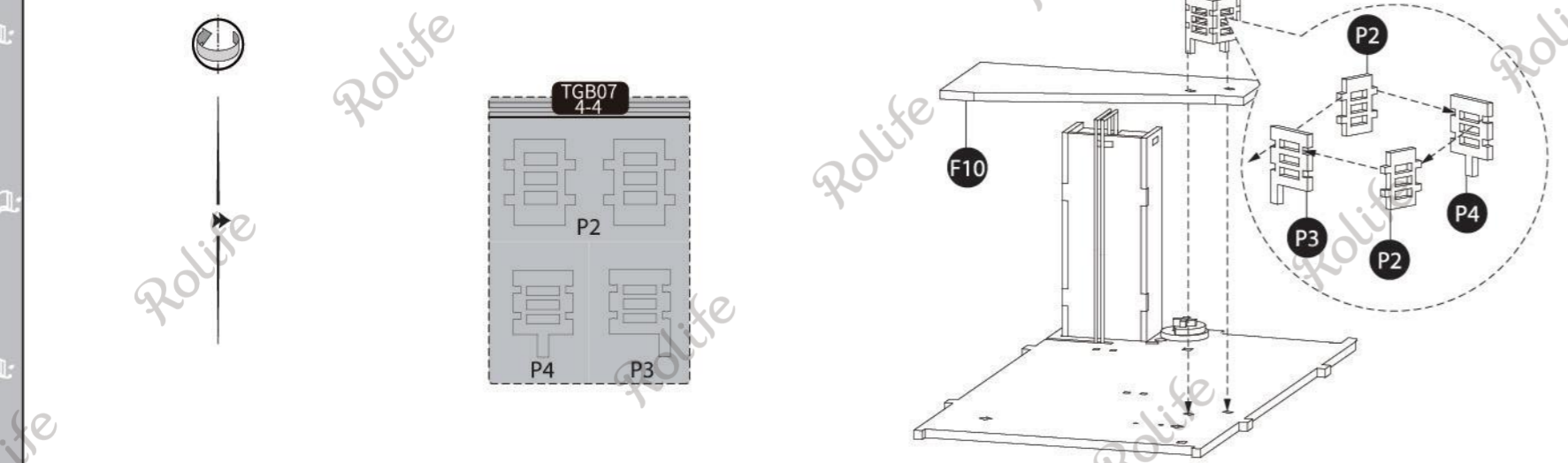

Remove the blue film on the front side before using.
 Entfernen Sie vor dem Gebrauch die blaue Folie auf der Vorderseite.
 Retirez le film bleu sur la face avant avant de l'utiliser.
 Rimuovere la pellicola blu sul lato anteriore prima dell'utilizzo.
 Retire la película azul en la parte frontal antes de usar.

Use the double-sided tape
 Verwenden Sie das doppelseitige Klebeband
 Utiliser le ruban adhésif double face
 Utilizzare il nastro biadesivo
 Use la cinta de doble faz

Non-film side
 Seite ohne Folie
 Côté sans film
 Lato senza pellicola
 Lado sin película

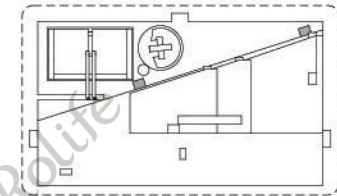

Hole illustration
Abbildung der Löcher
Illustration des trous
Illustrazione dei fori
Ilustración del orificio

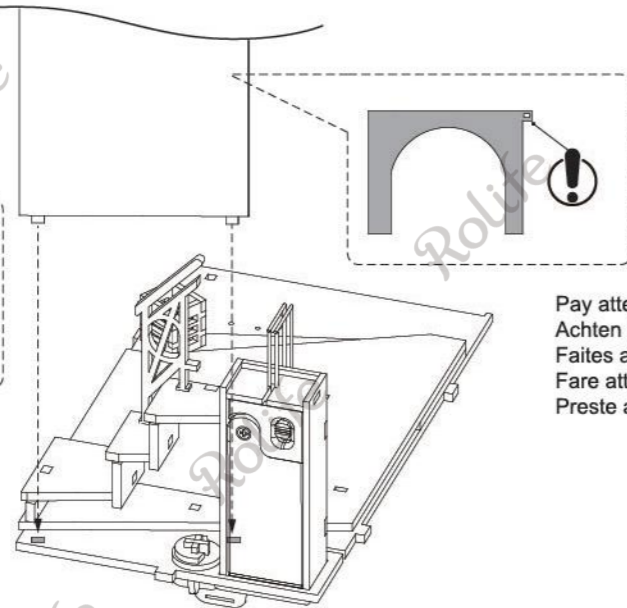

Pay attention to the direction.
Achten Sie auf die Richtung.
Faites attention à la direction.
Fare attenzione alla direzione.
Preste atención a la dirección.

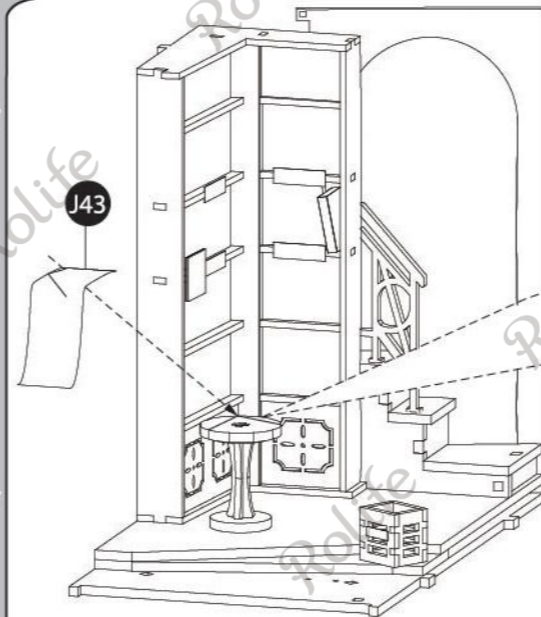
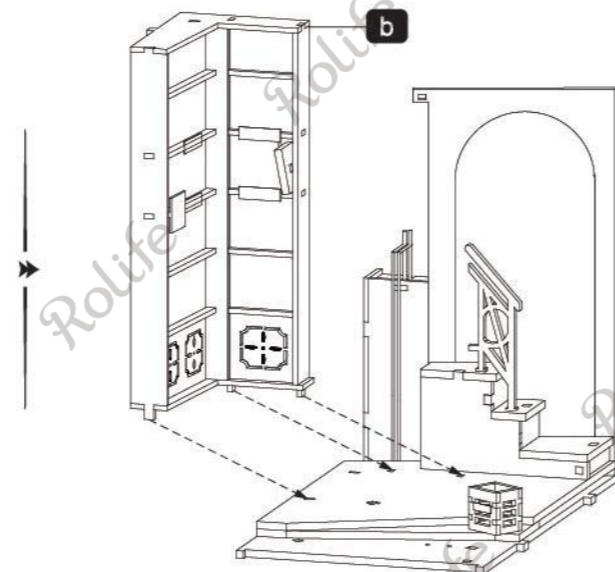
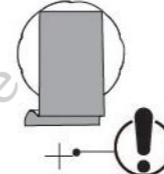
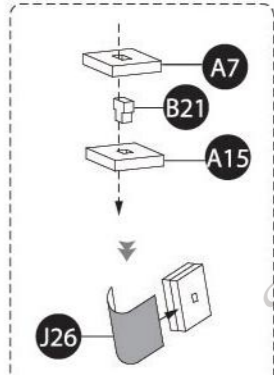
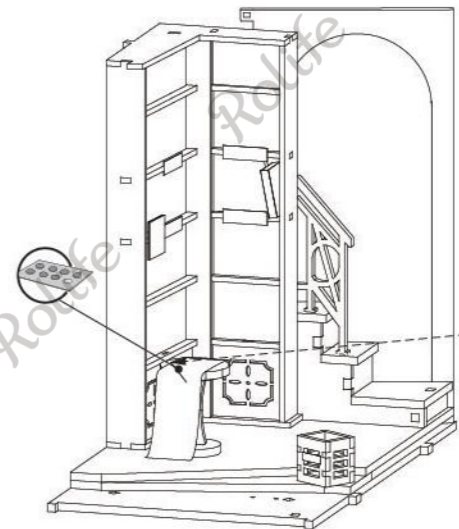

Illustration
Abbildung
Illustration
Illustrazione
Ilustración



Do not cover the pattern +.
Decken Sie den mit dem Muster +
markierten Teil nicht ab.
Ne recouvrez pas la partie marquée
du motif +.
Non coprire il disegno +.
No cubra el patrón +.



Align with lines to assemble.
Zum Zusammenbau an den
Linien ausrichten.
Pour l'assemblage, alignez-la
sur les lignes.
Allineare con le linee per
l'assemblaggio.
Alinee con las líneas para
montar.

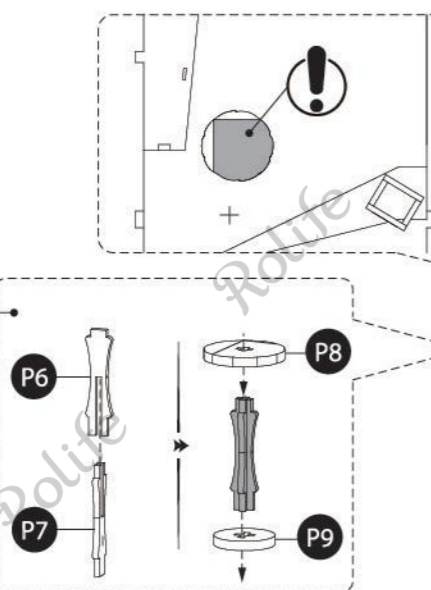
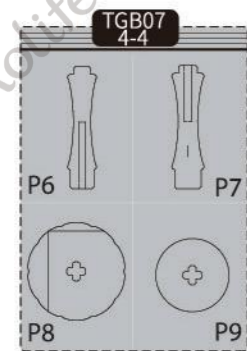

Pay attention to the
direction.
Achten Sie auf die Richtung.
Faites attention à la
direction.
Fare attenzione alla
direzione.
Preste atención a la
dirección.

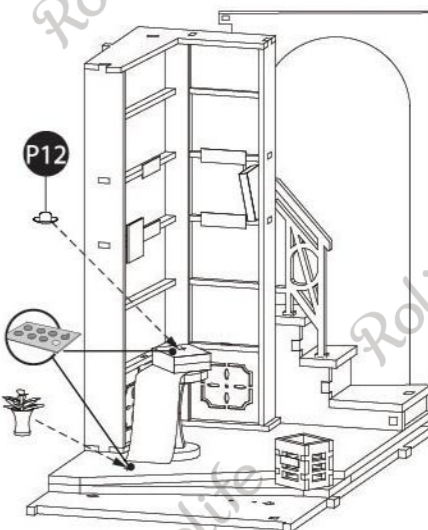
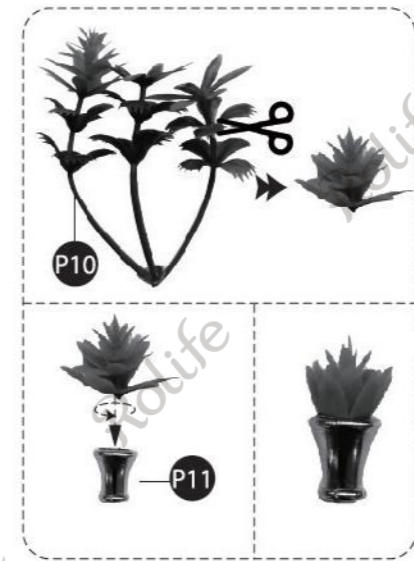

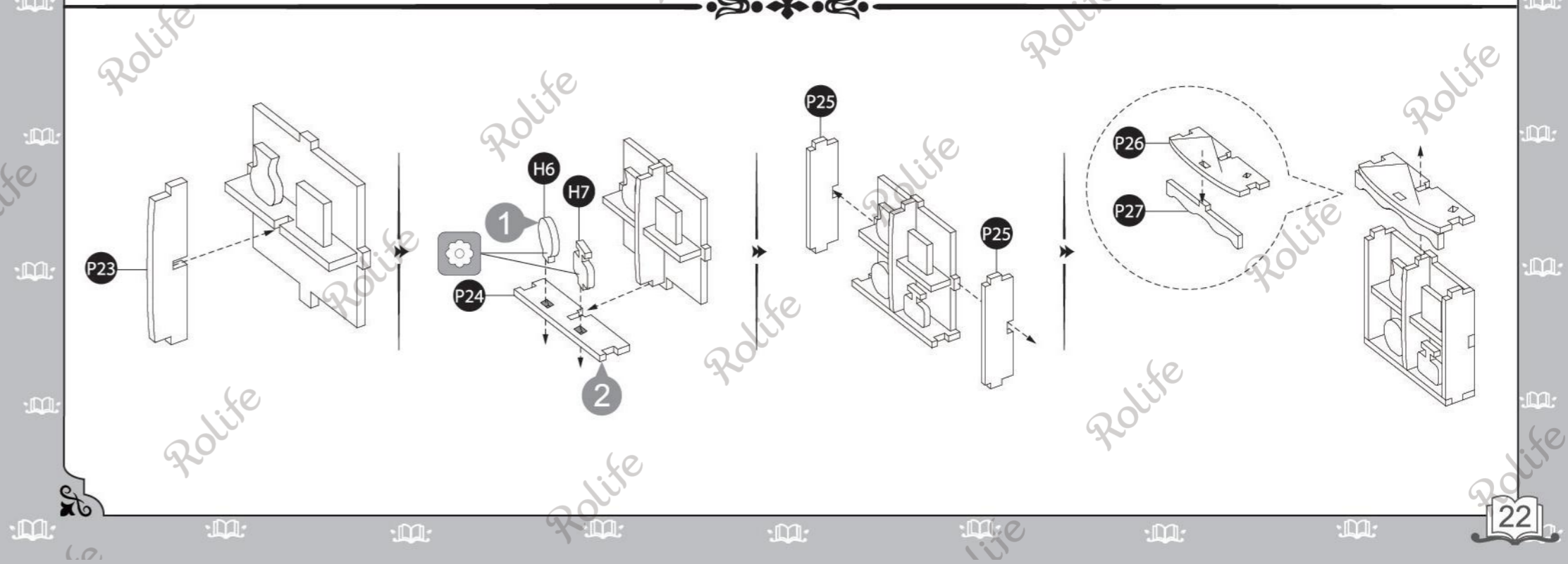
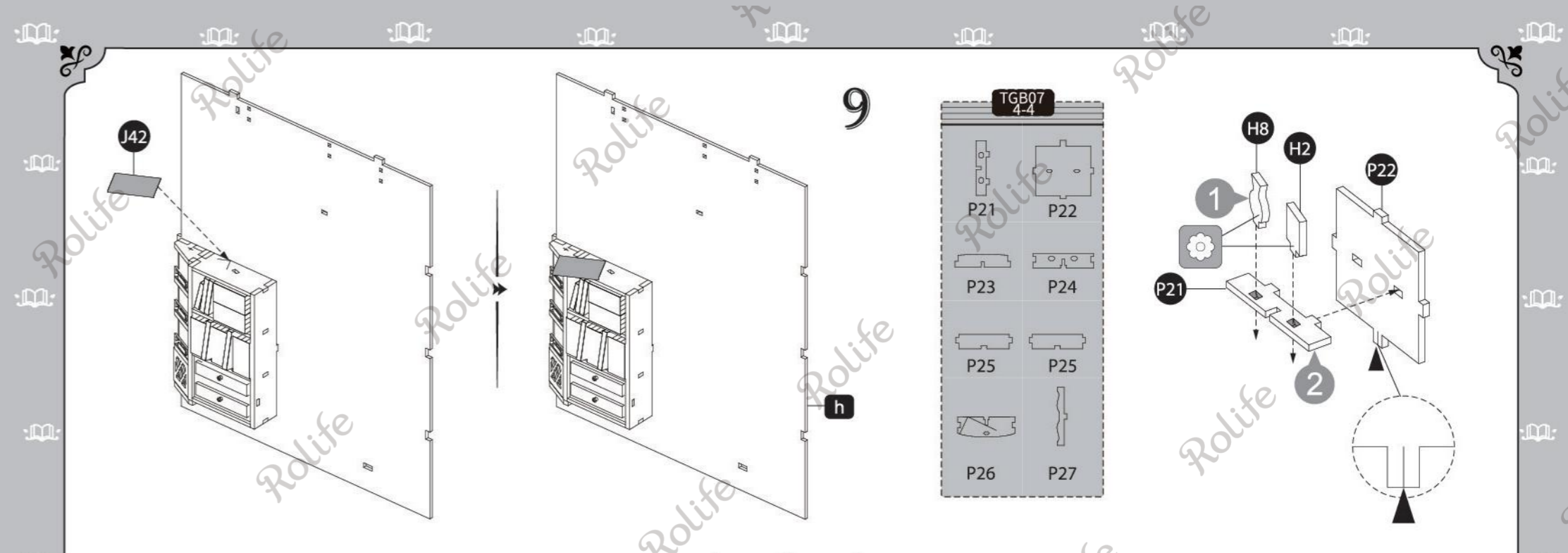
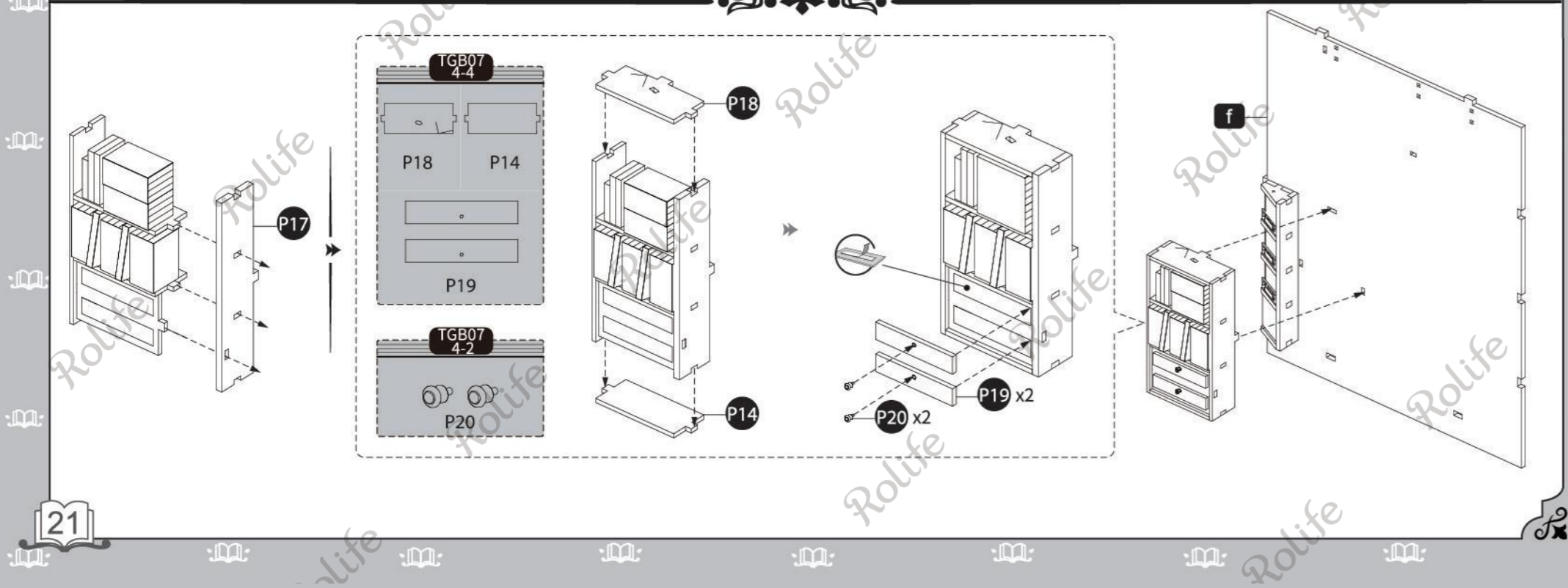
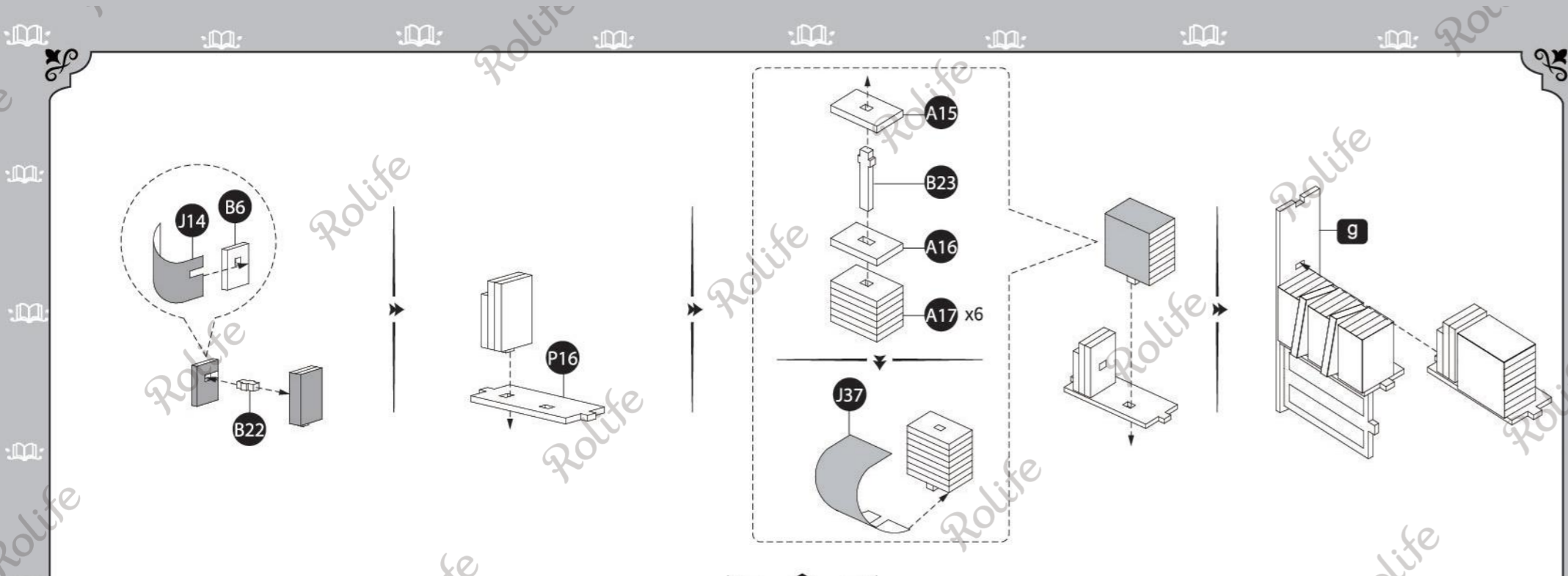

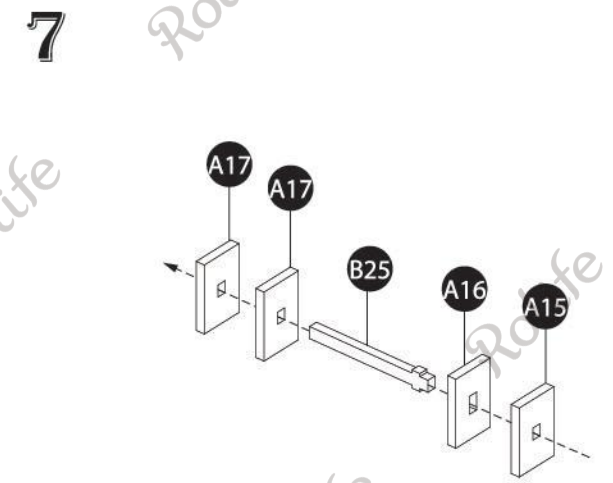
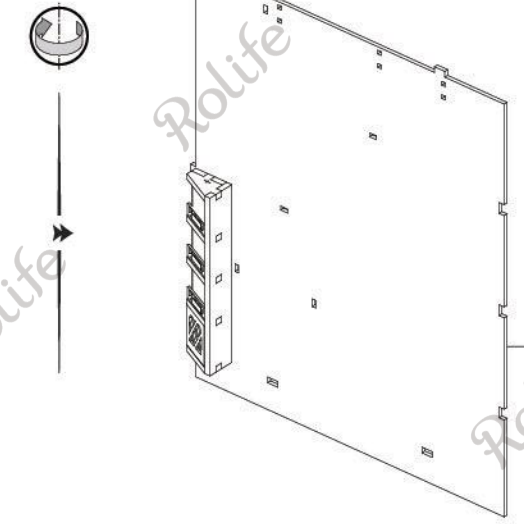
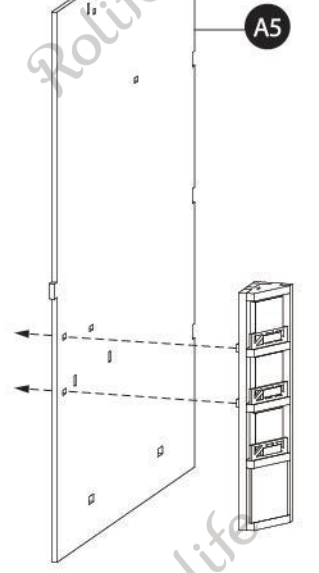
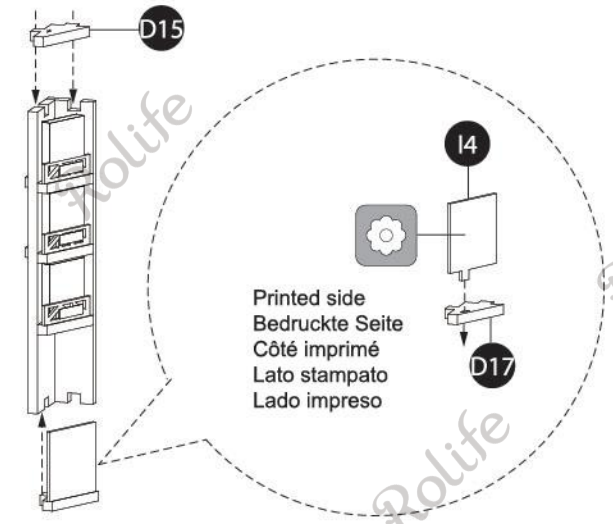
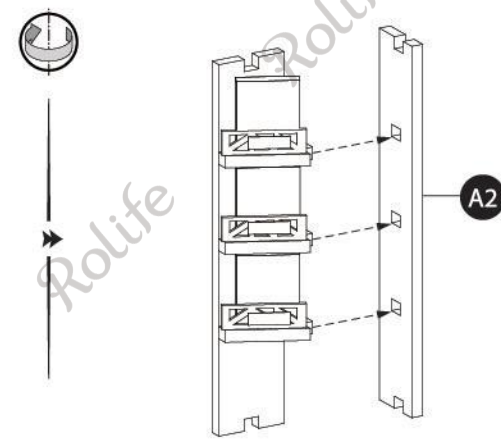

! B9 is the spare part of A17.
 B9 ist das Ersatzteil von A17.
 B9 est la pièce de rechange de A17.
 B9 è il pezzo di ricambio di A17.
 B9 es repuesto de A17.

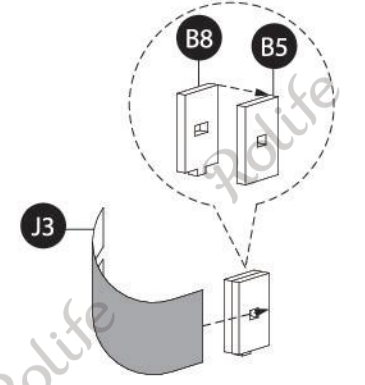
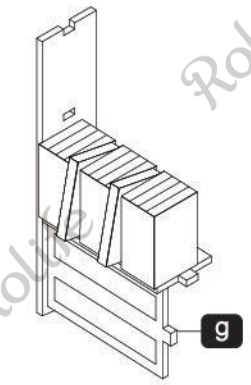
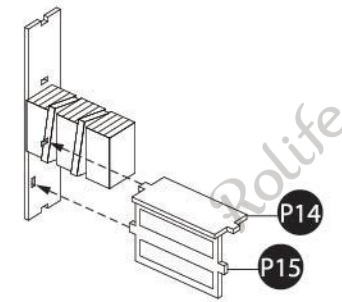
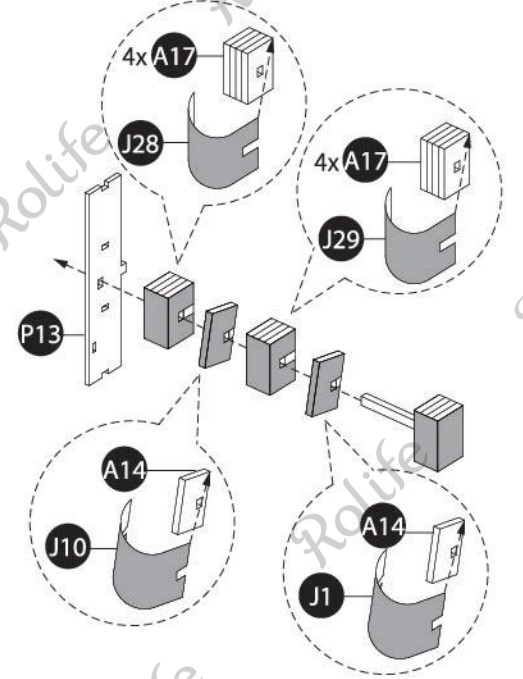
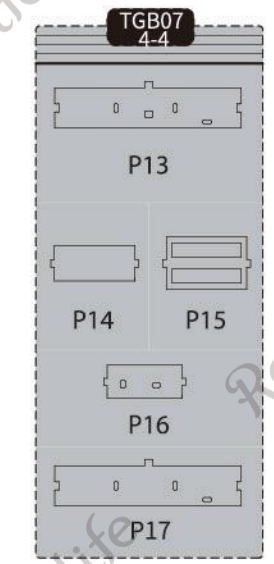
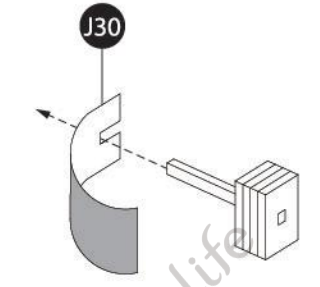

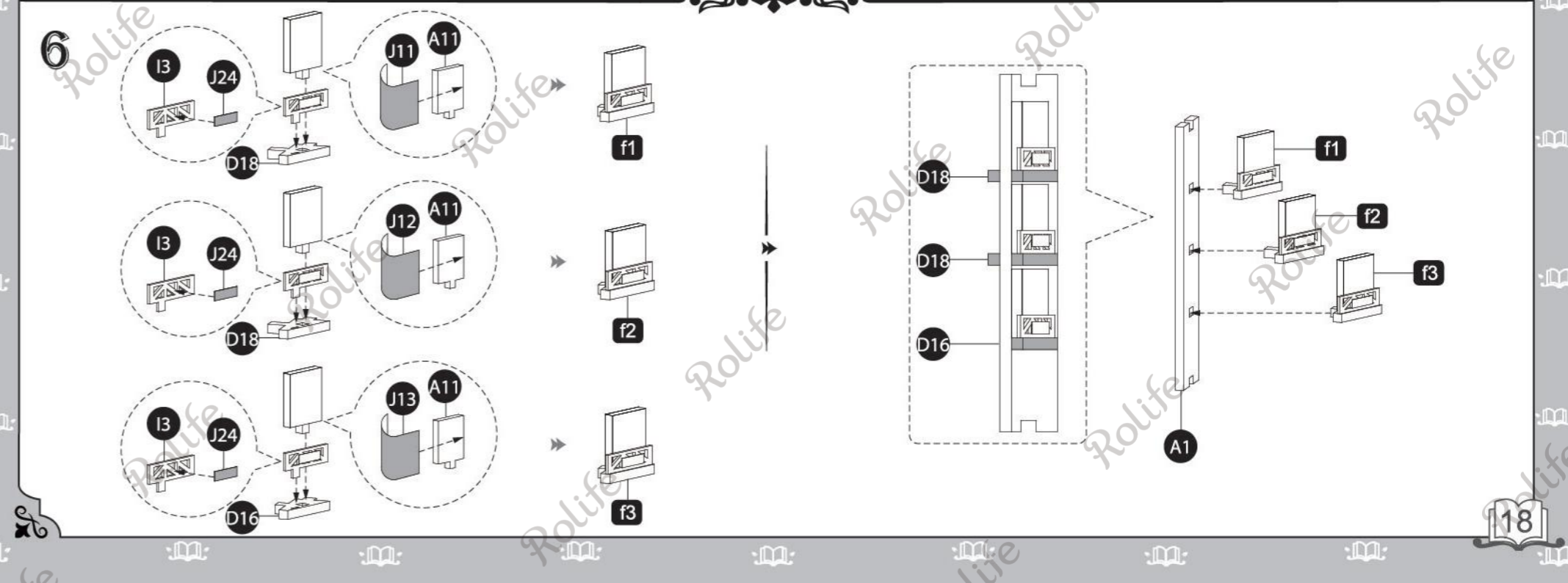
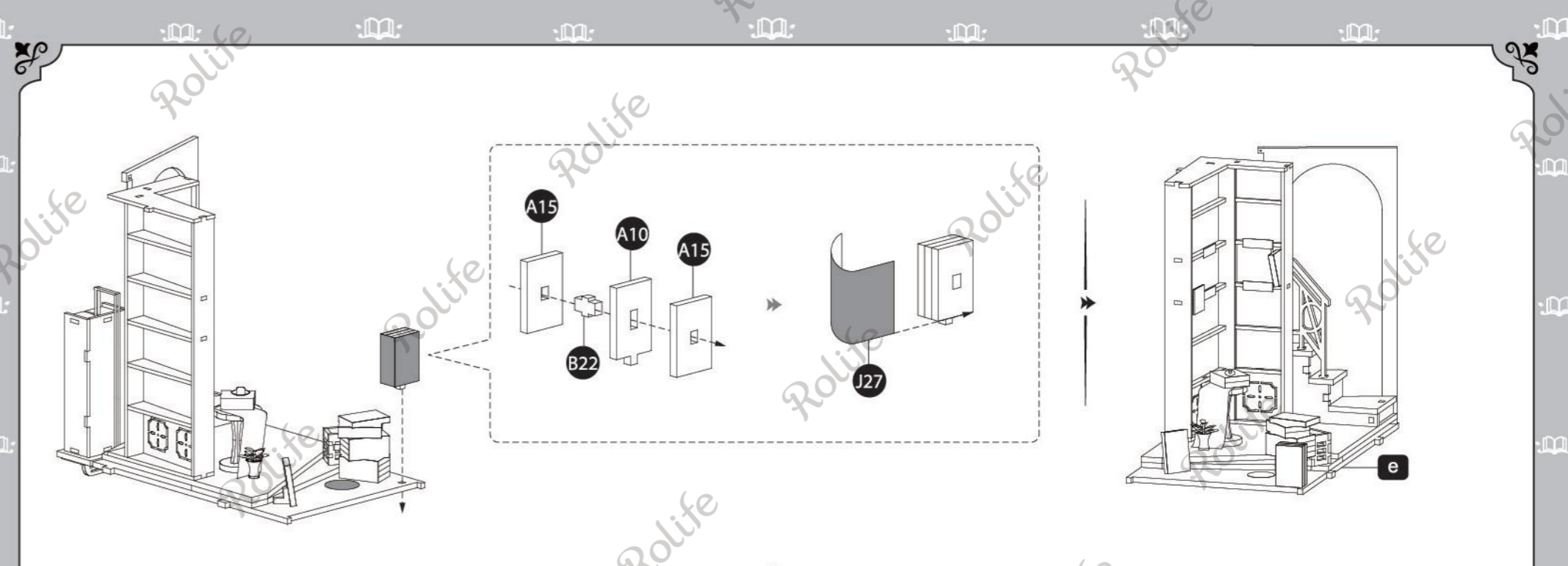
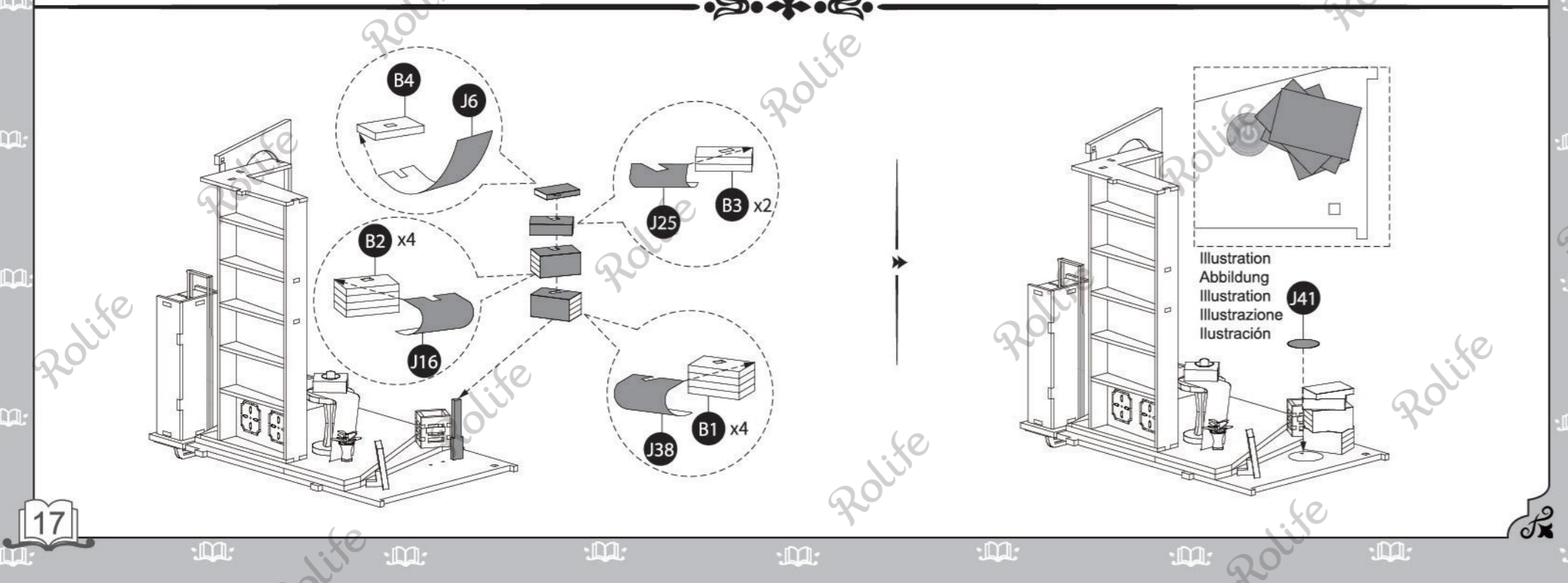
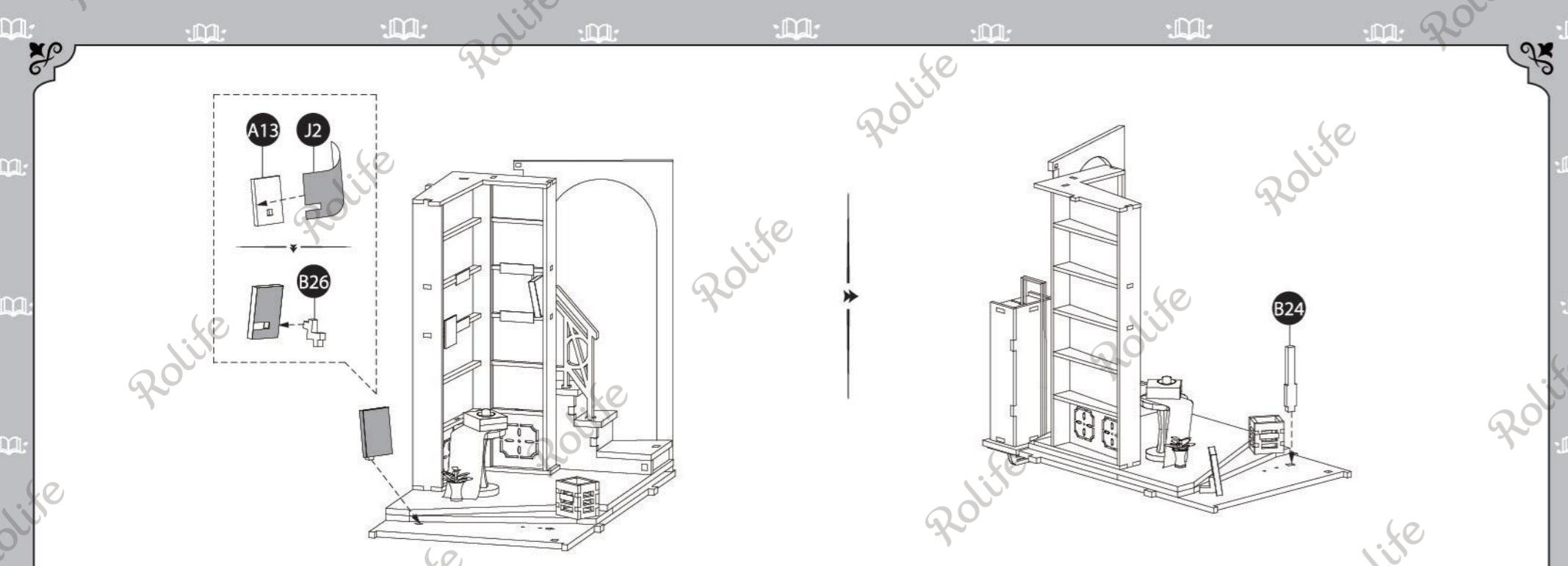

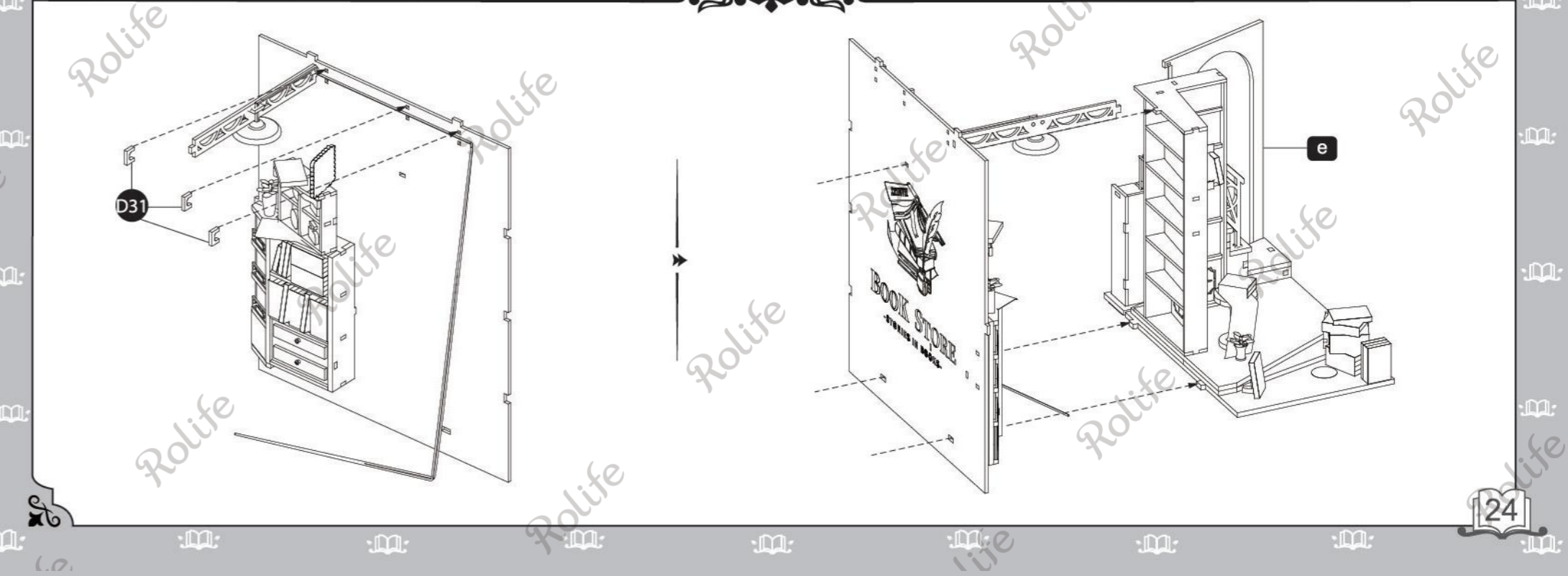
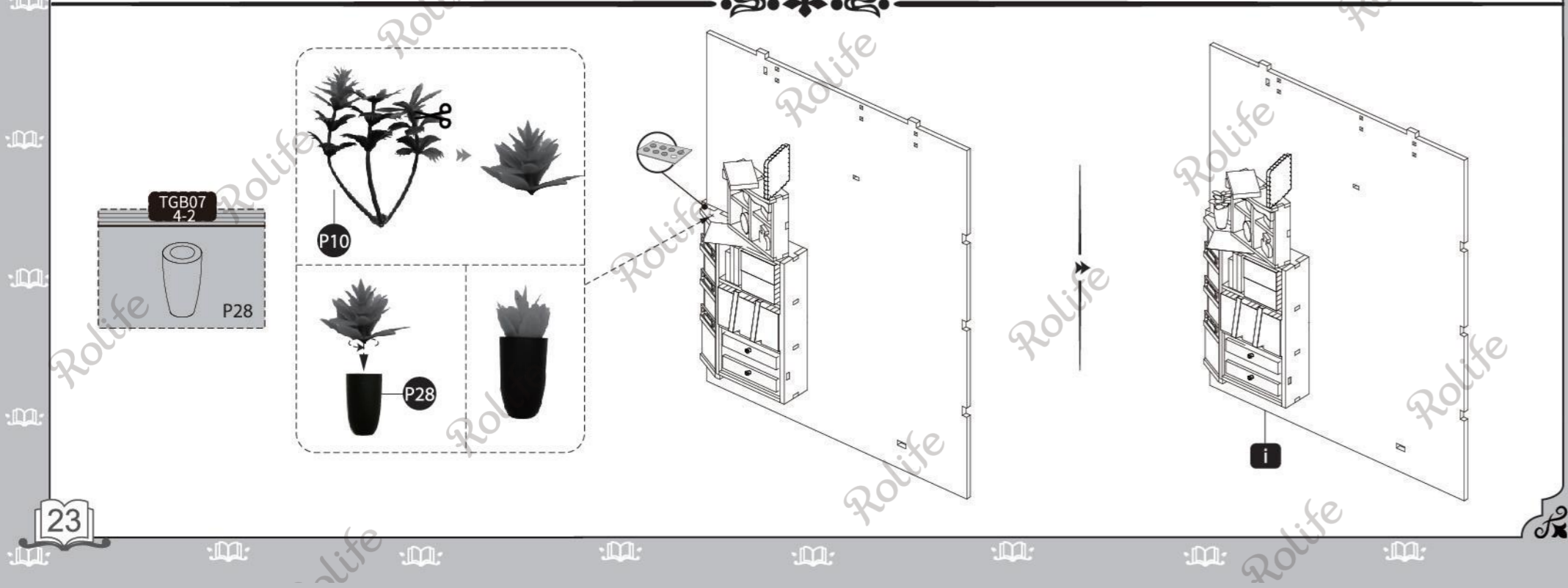
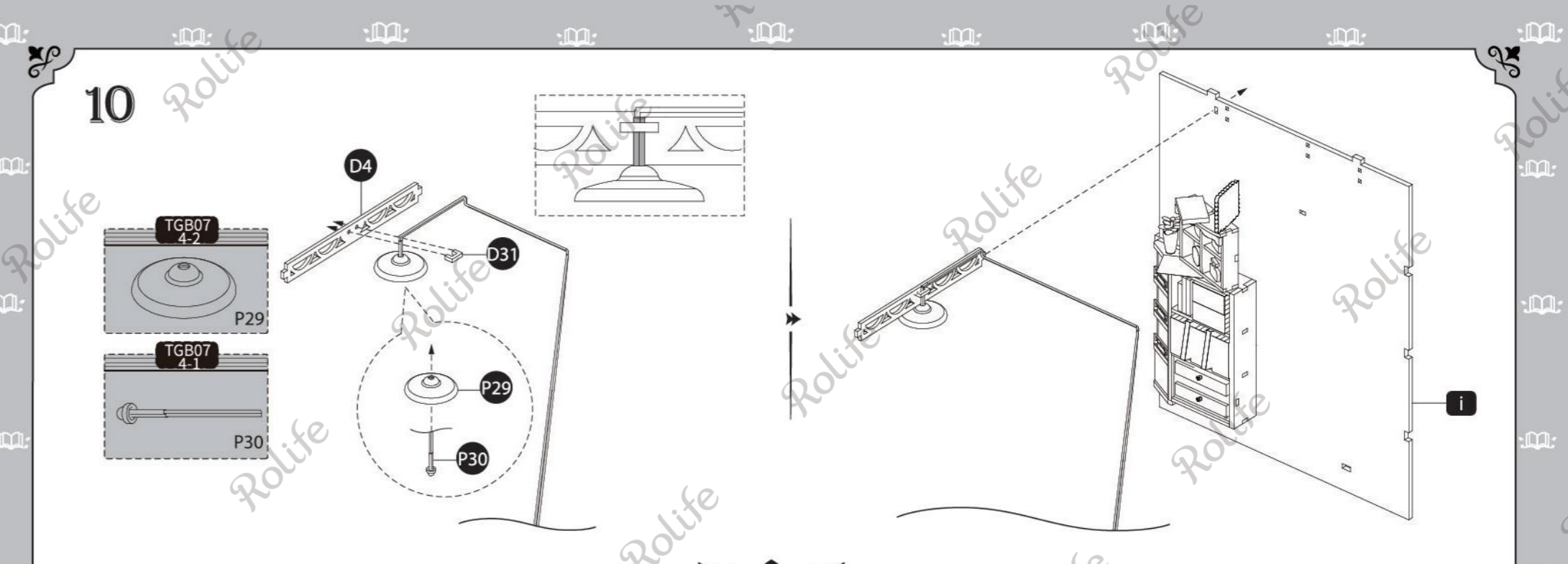
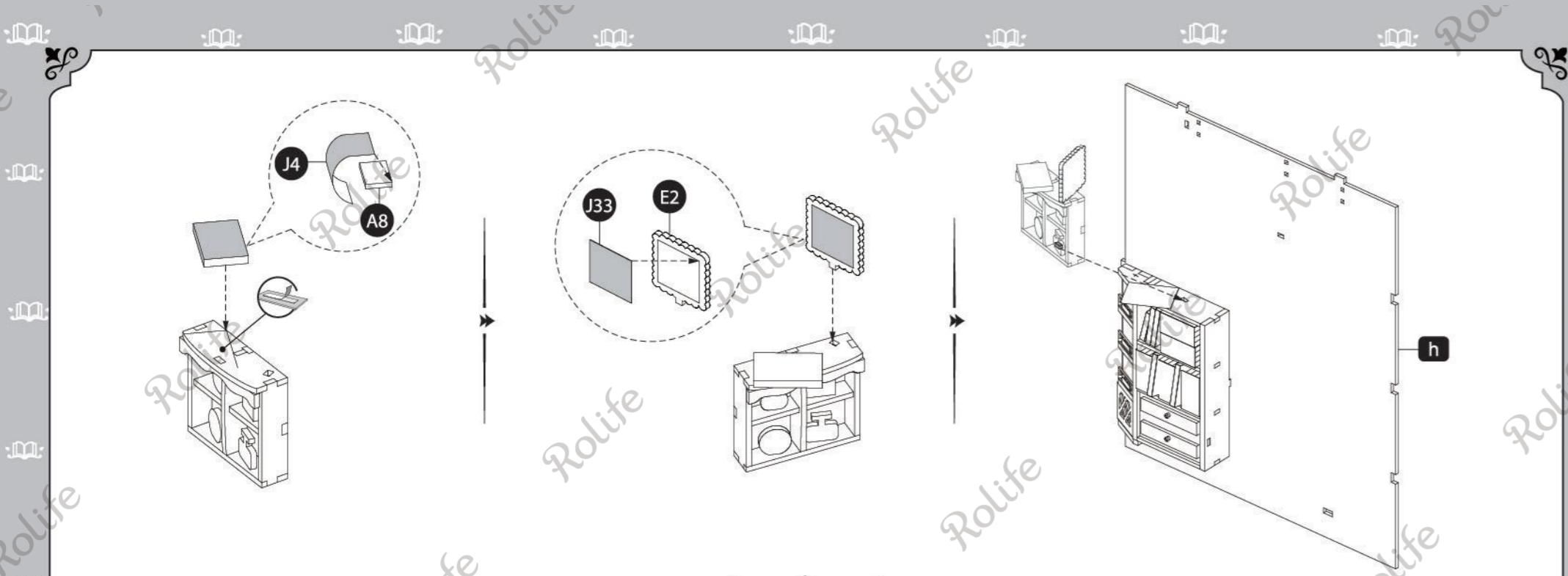

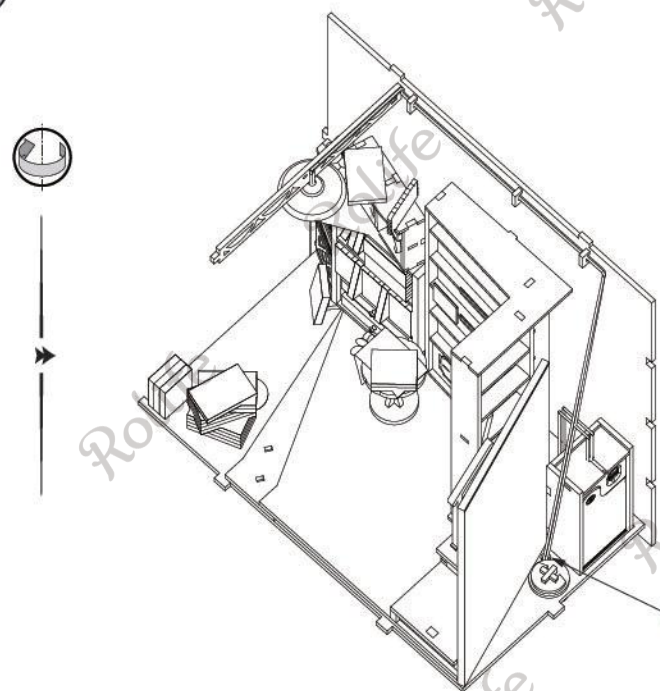

Pass the wire through this hole.
Führen Sie den Draht durch dieses Loch.
Faites passer le fil par ce trou.
Far passare il filo attraverso il foro.
Pase el cable a través de este orificio.

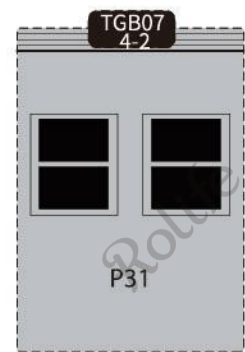

Scan for assembling videos
Scannen Sie es für Montagevideos
Scannez-le pour voir des vidéos de montage
Scansionare per i video di montaggio
Escanee vídeos de montaje

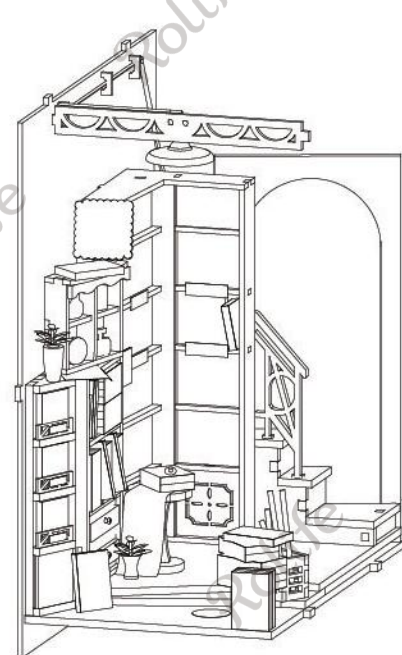

B19

G

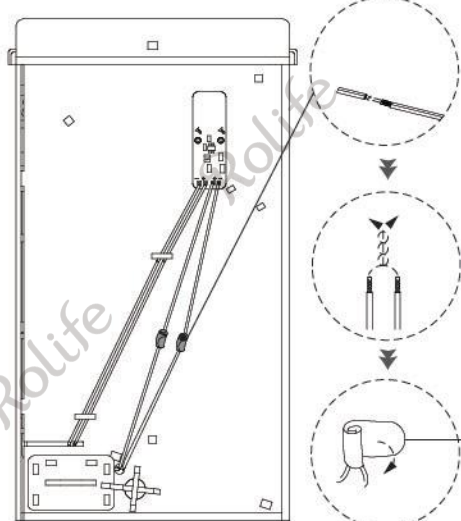
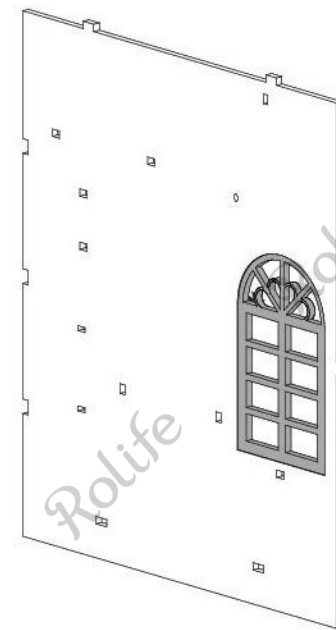

Connect wires with the same colors together. Do not connect them incorrectly.
Verbinden Sie Drähte mit den gleichen Farben miteinander. Schließen Sie sie nicht falsch an.
Reliez entre eux des fils de même couleur. Ne les connectez pas de manière incorrecte.
Collegare tra loro i fili dello stesso colore. Non collegarli in modo errato.
Conecte los cables de los mismos colores juntos. No los conecte incorrectamente.



Remove the partial cover of red and black wires before connecting as shown.
Entfernen Sie ein kleines Stück isolierendes Plastik von den Enden der roten und schwarzen Drähte, bevor Sie sie wie gezeigt anschließen.
Retirez un petit morceau de plastique isolant des extrémités des fils rouge et noir avant de les connecter comme indiqué.
Rimuovere la copertura parziale dei fili rossi e neri prima di effettuare il collegamento come illustrato.
Retire la cubierta parcial de los cables rojo y negro antes de conectarlos como se indica.

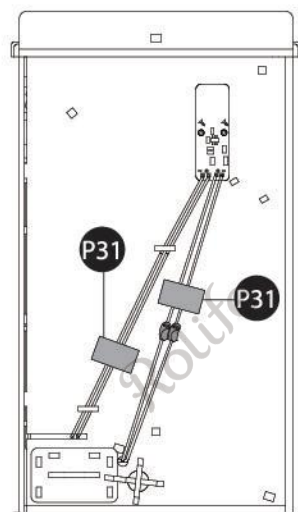

Stick the loose wires onto the bottom with the insulating tape after testing.
Kleben Sie die losen Drähte nach dem Testen mit dem Isolierband auf den Boden.
Après les avoir testés, collez les fils détachés sur le sol avec le ruban isolant.
Dopo aver effettuato un test di prova, incollare i fili allentati sul fondo con il nastro isolante.
Pegue los cables sueltos en la parte inferior con la cinta aislante después de la prueba.

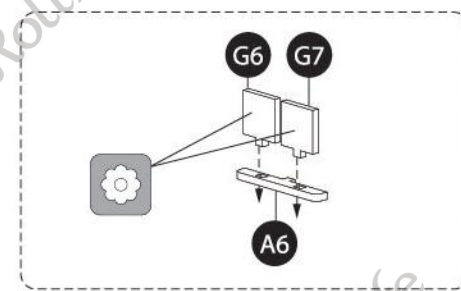

G2

G3

A6

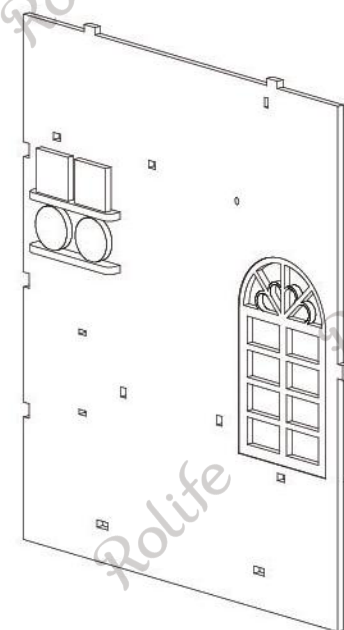
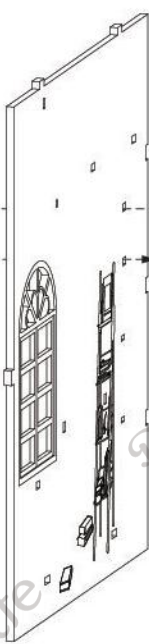

k

11

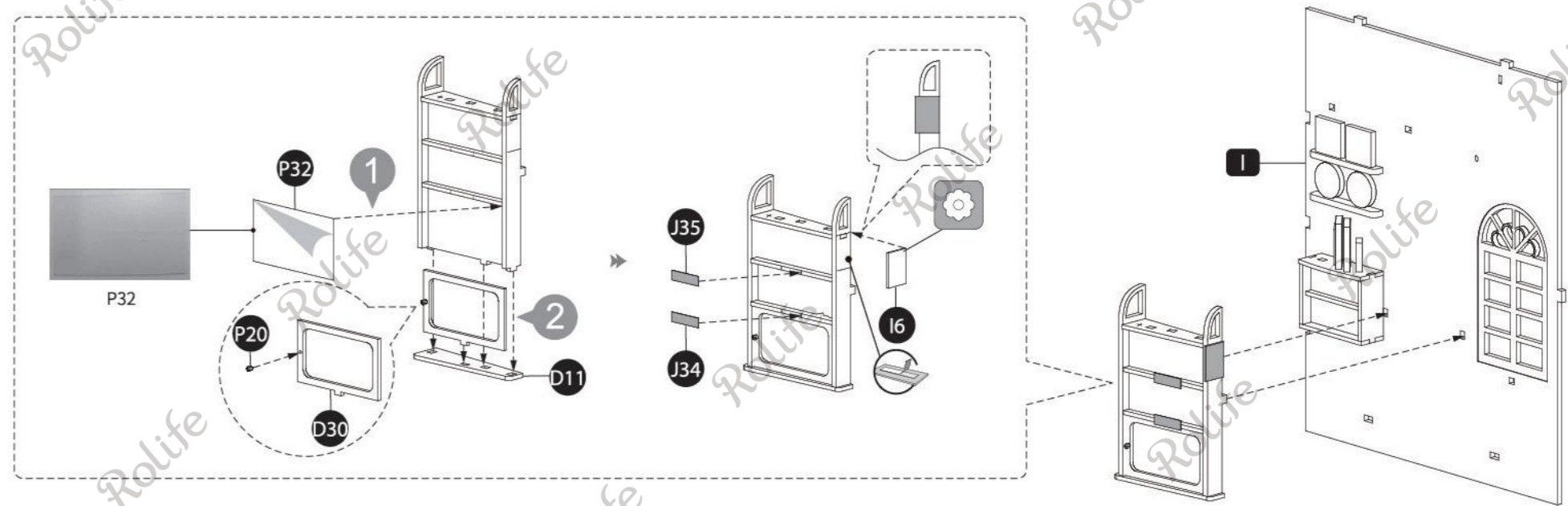
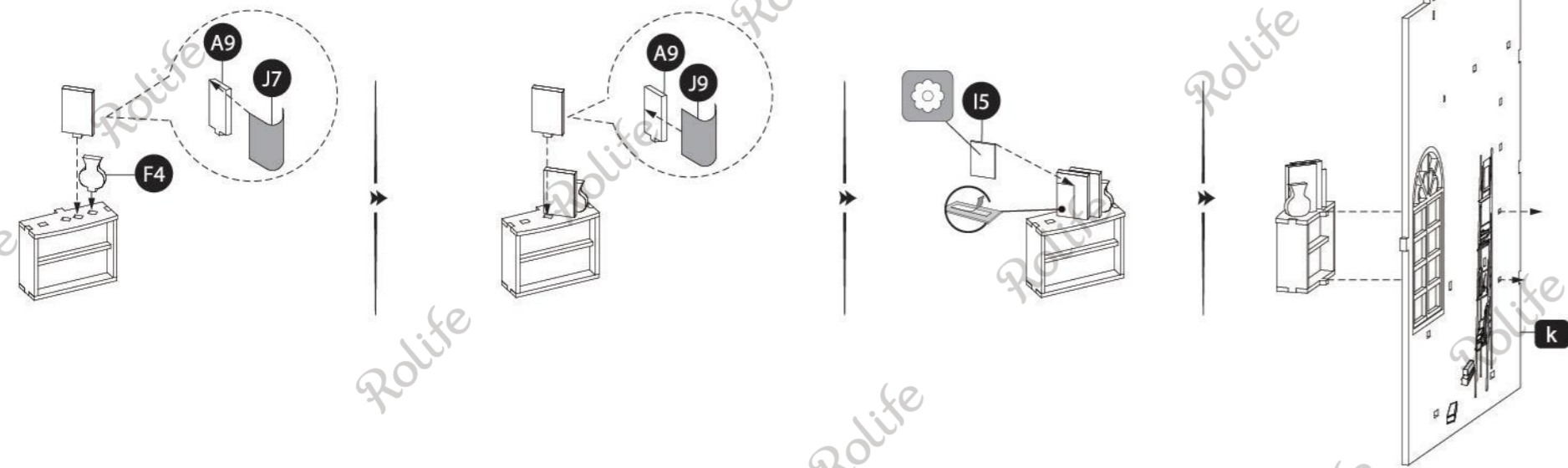
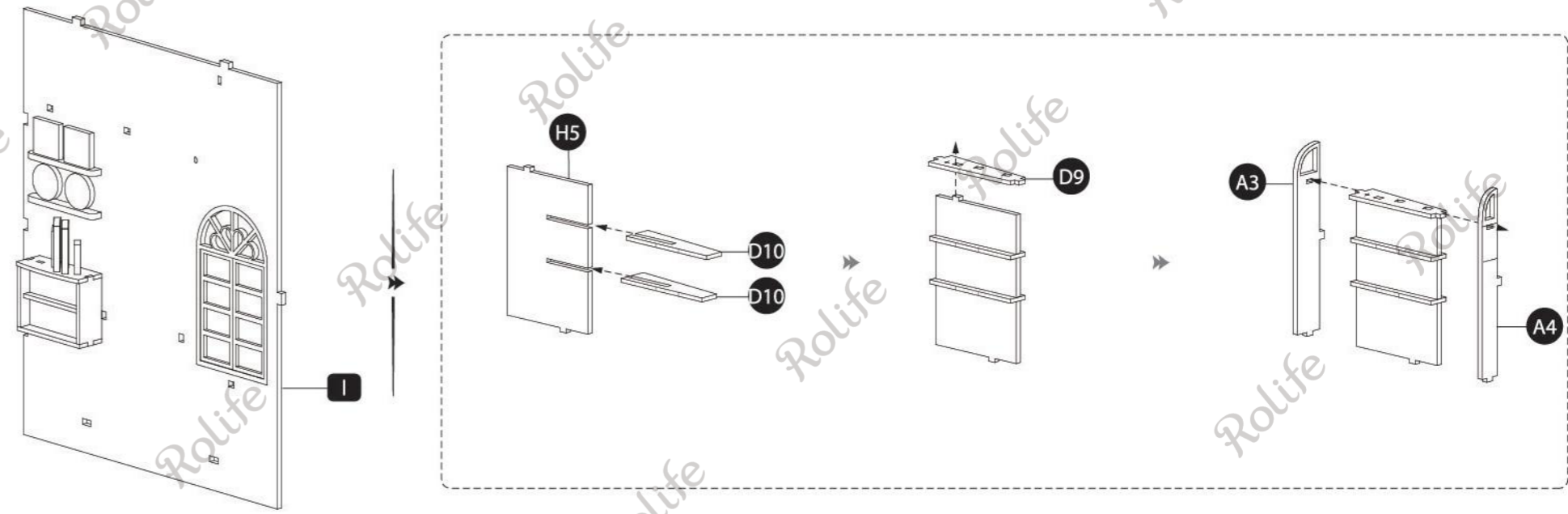
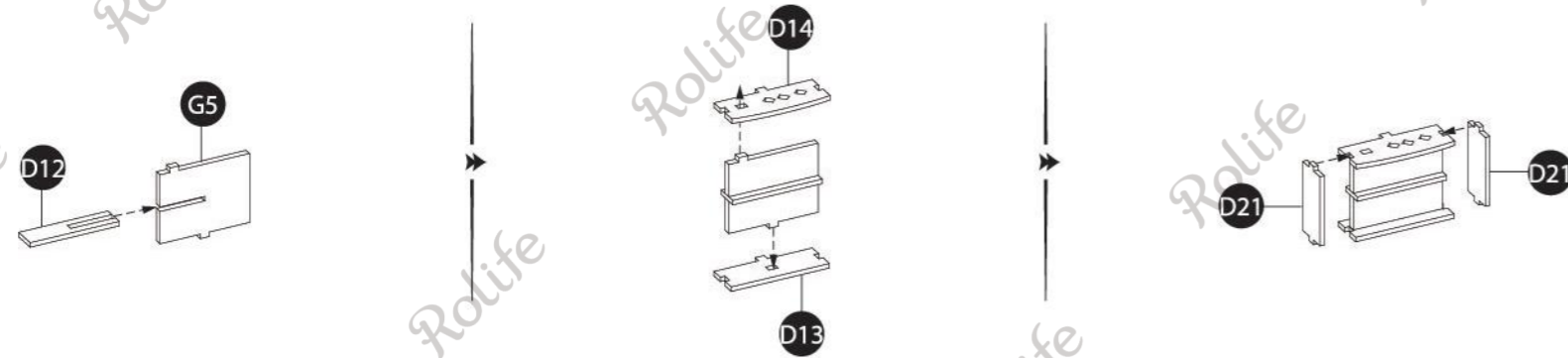

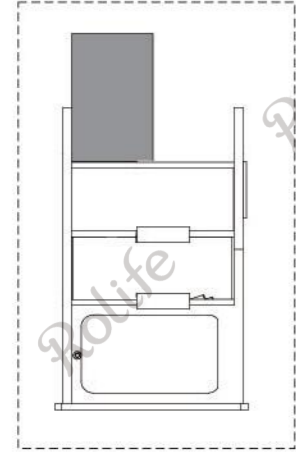
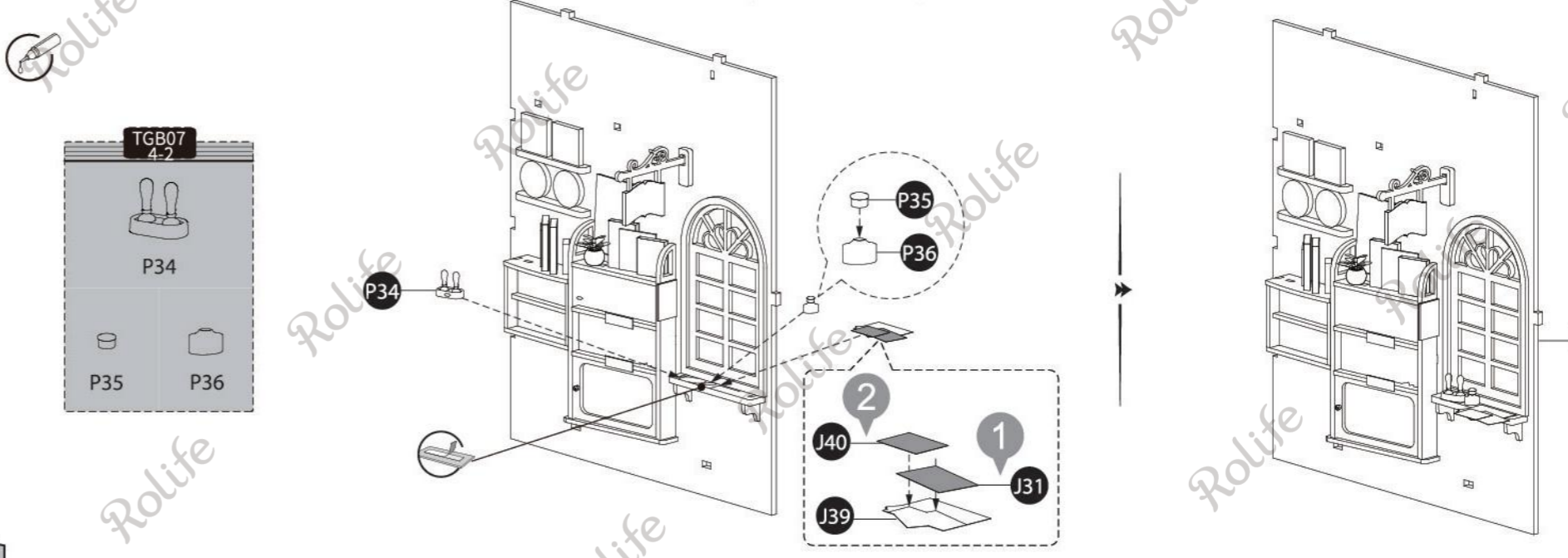
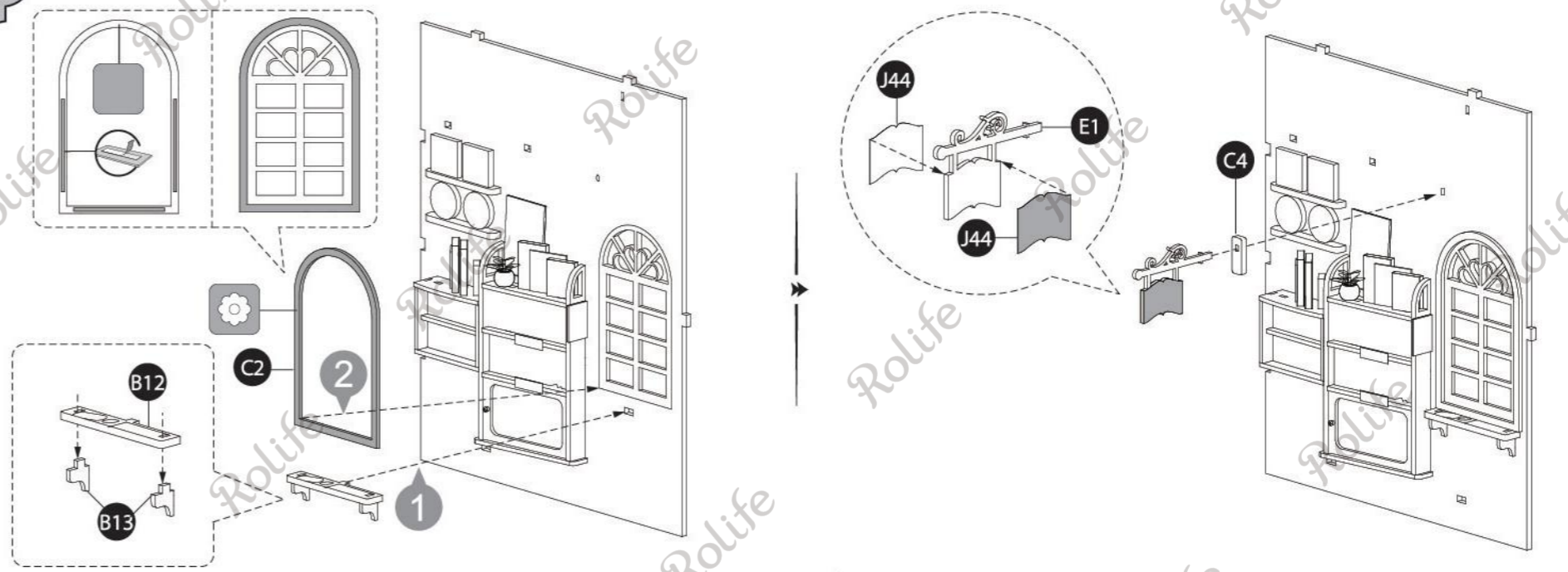
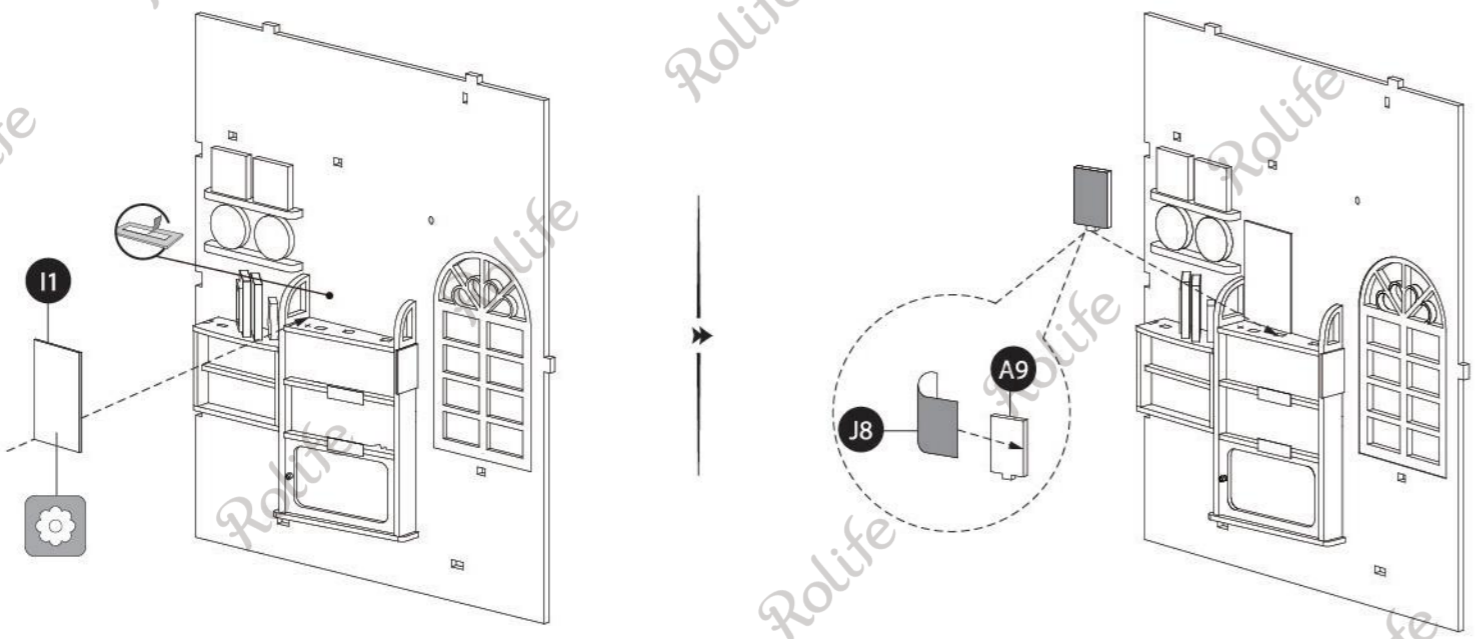
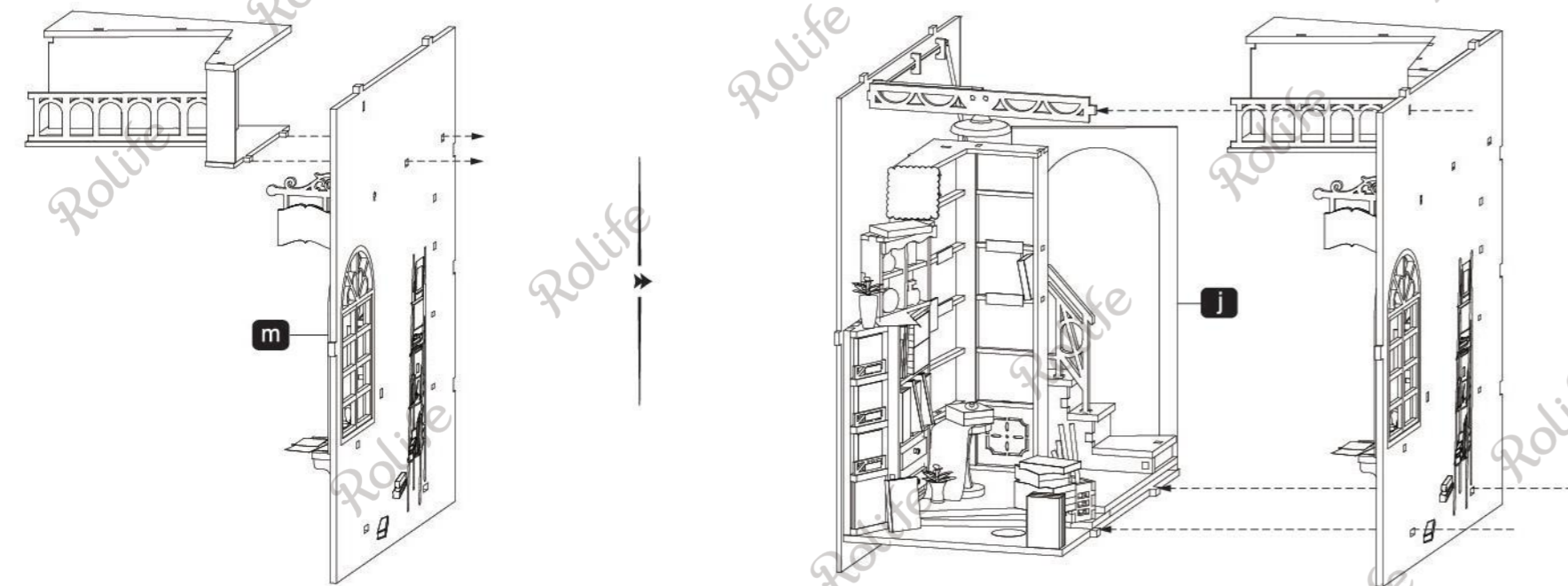
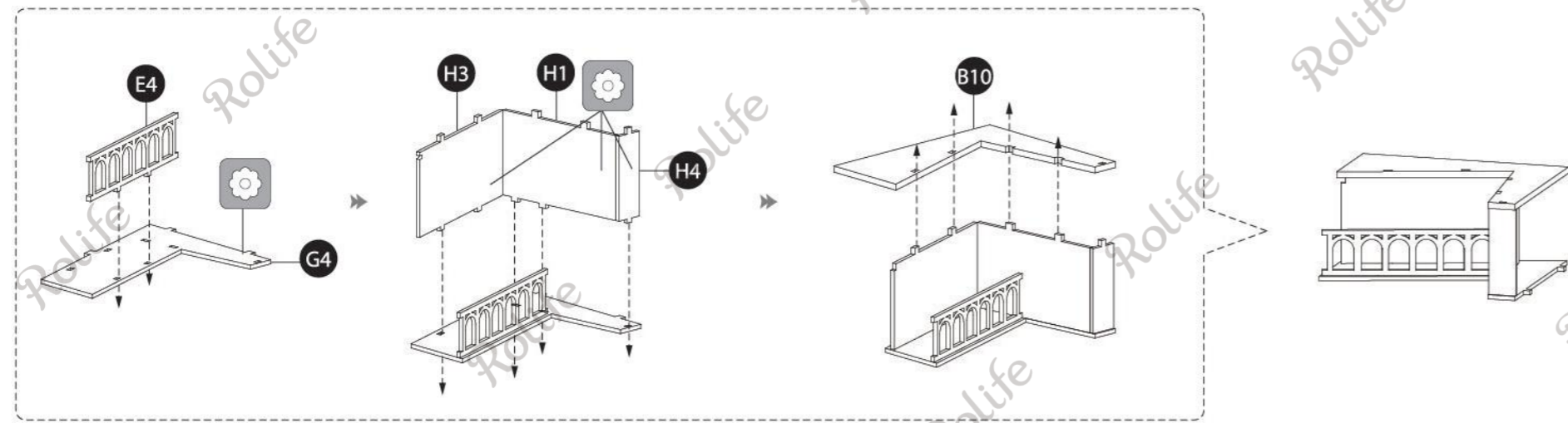
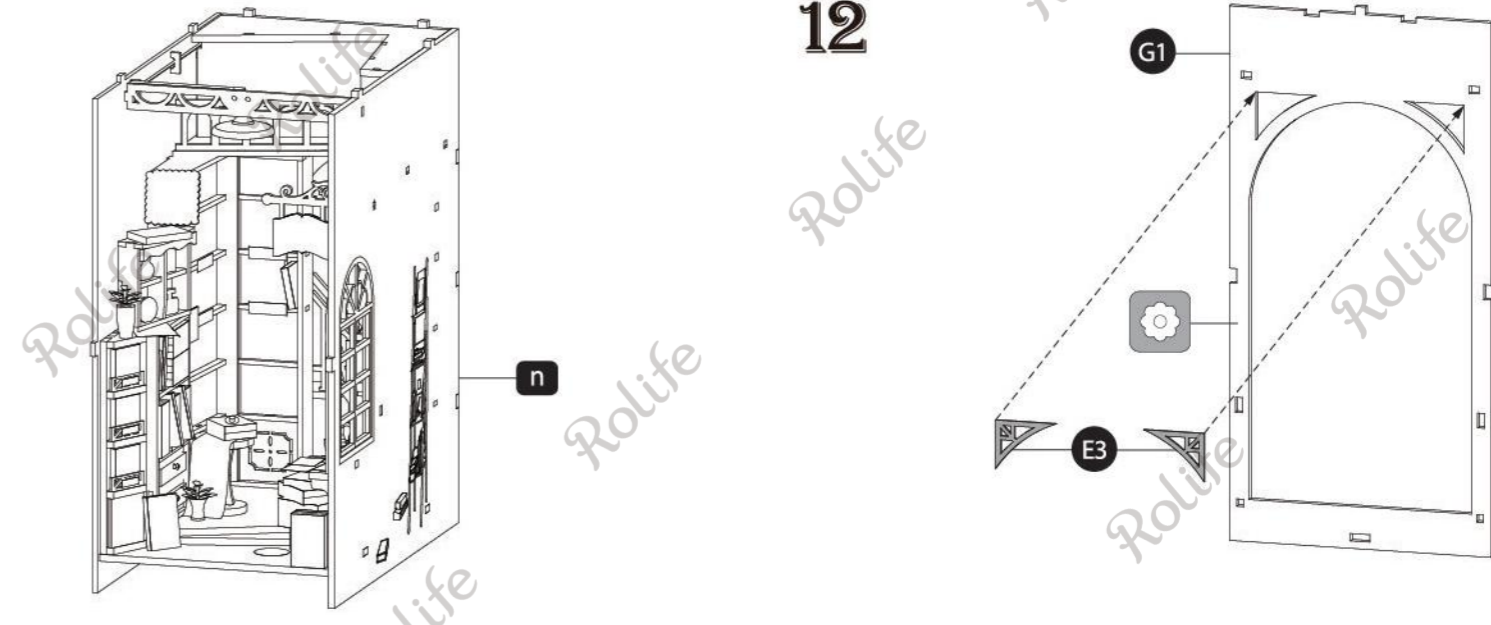
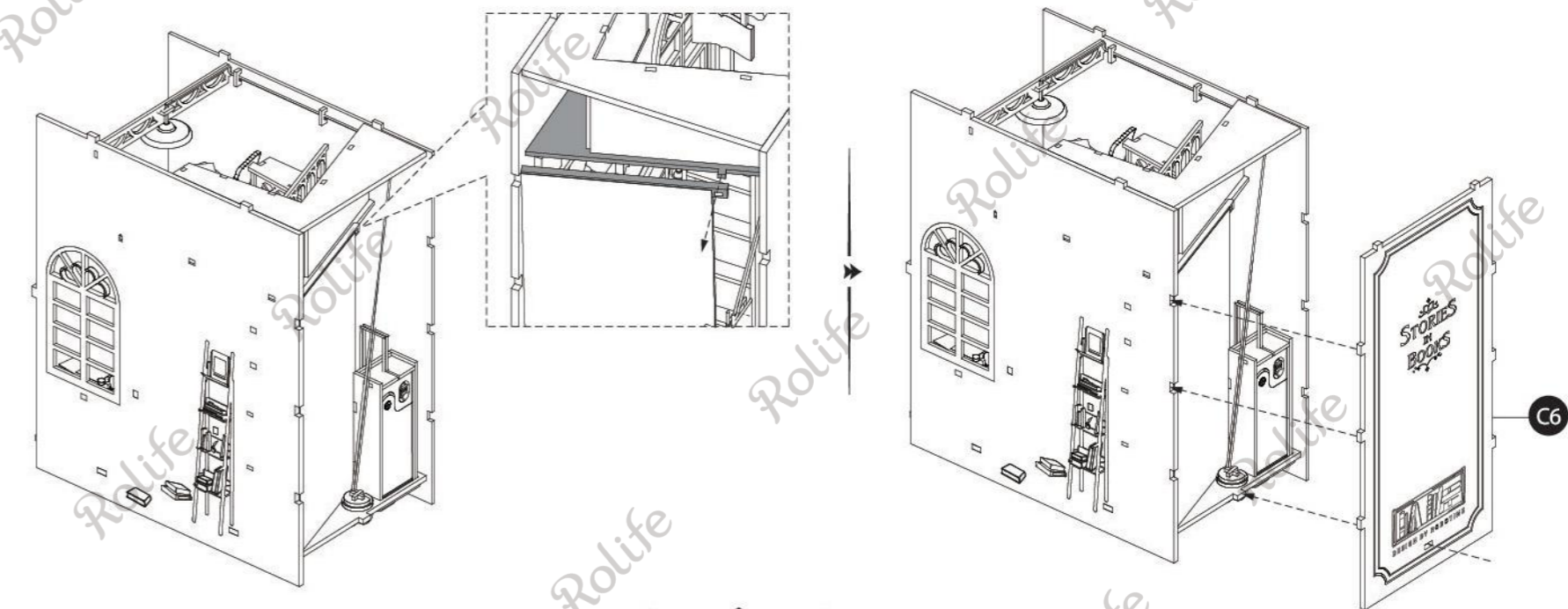

Illustration
Abbildung
Illustration
Ilustración





31



12

32

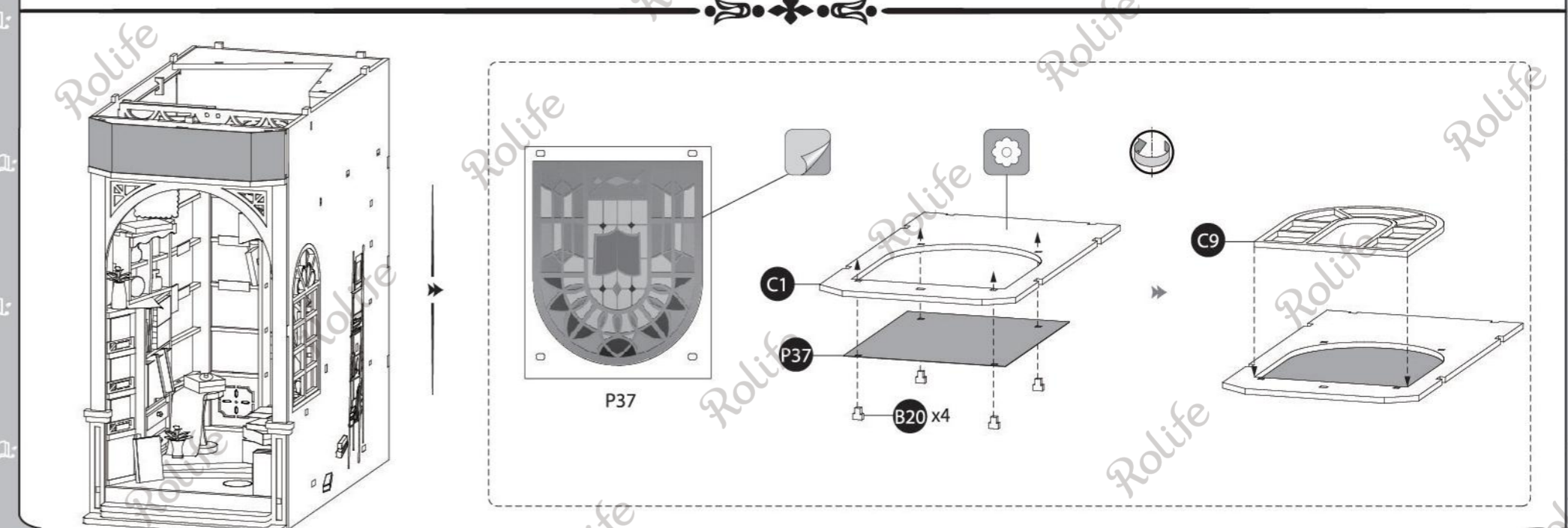
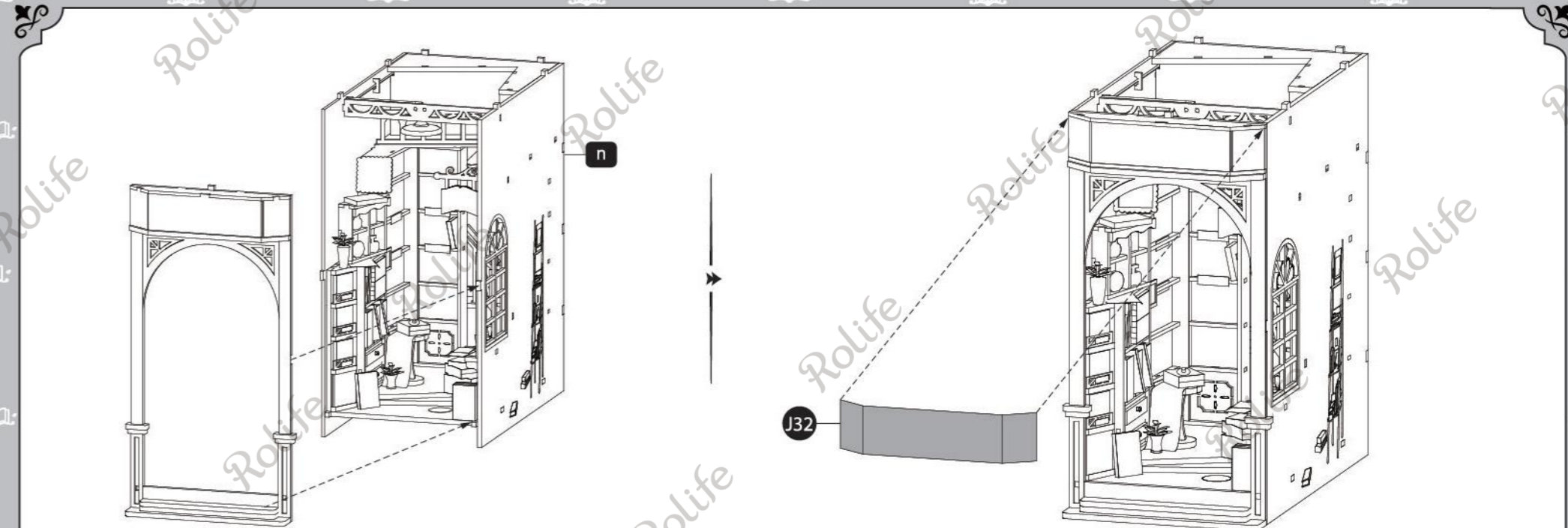
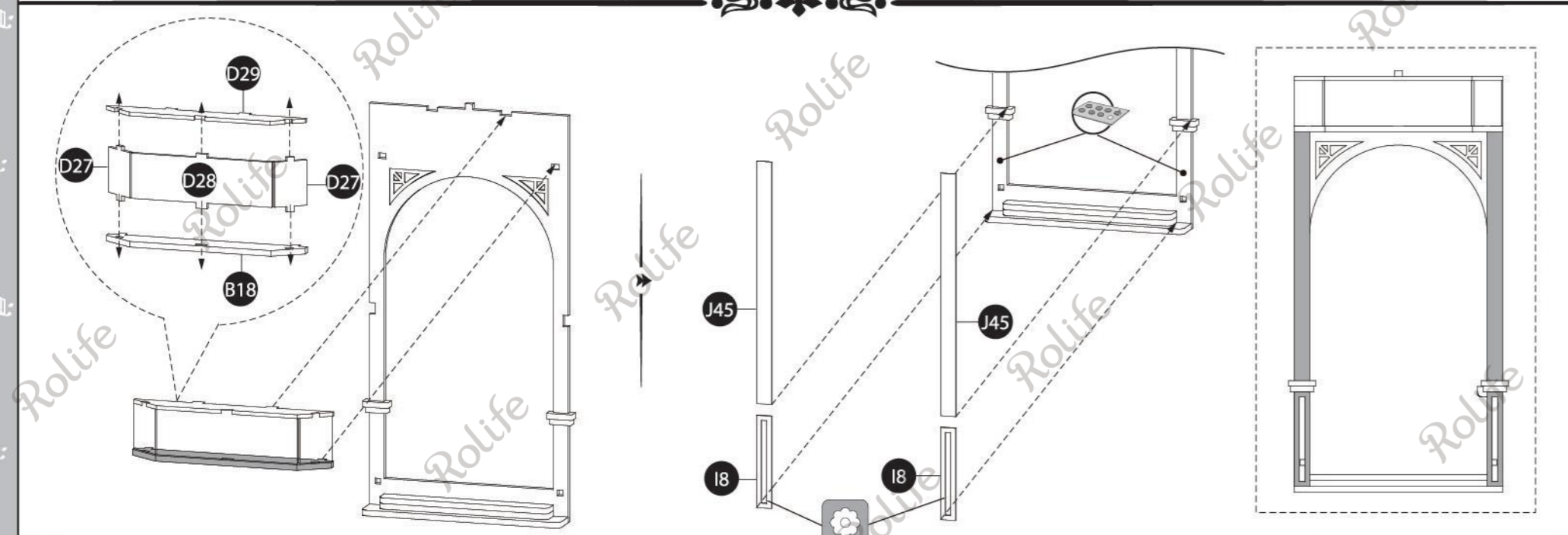
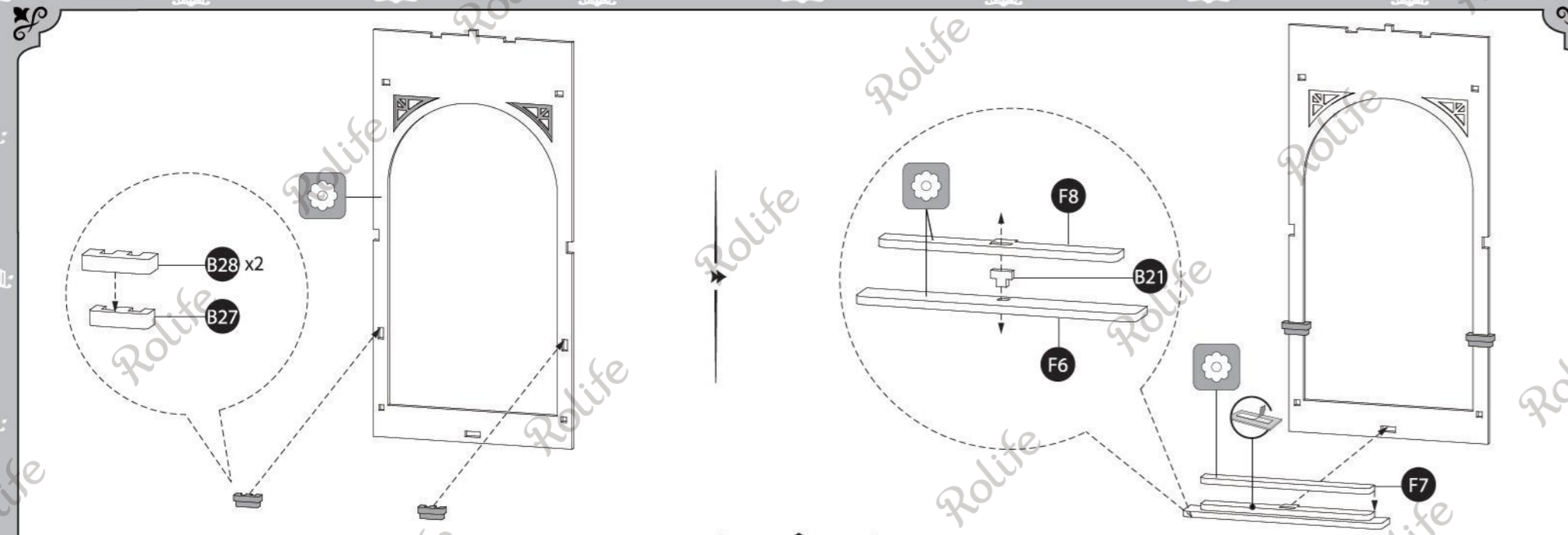

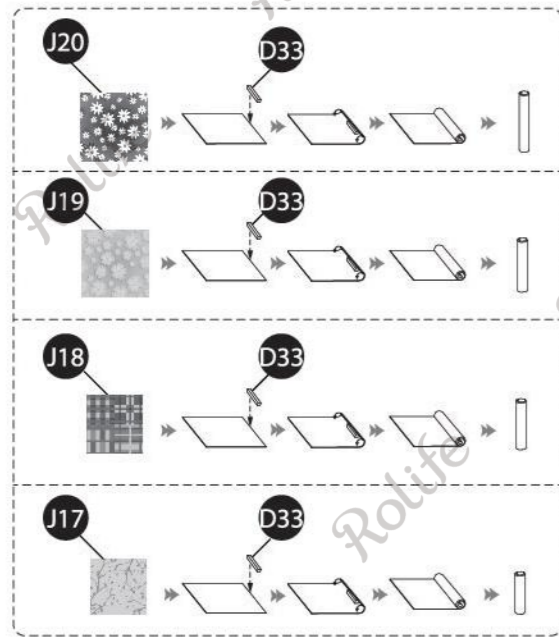
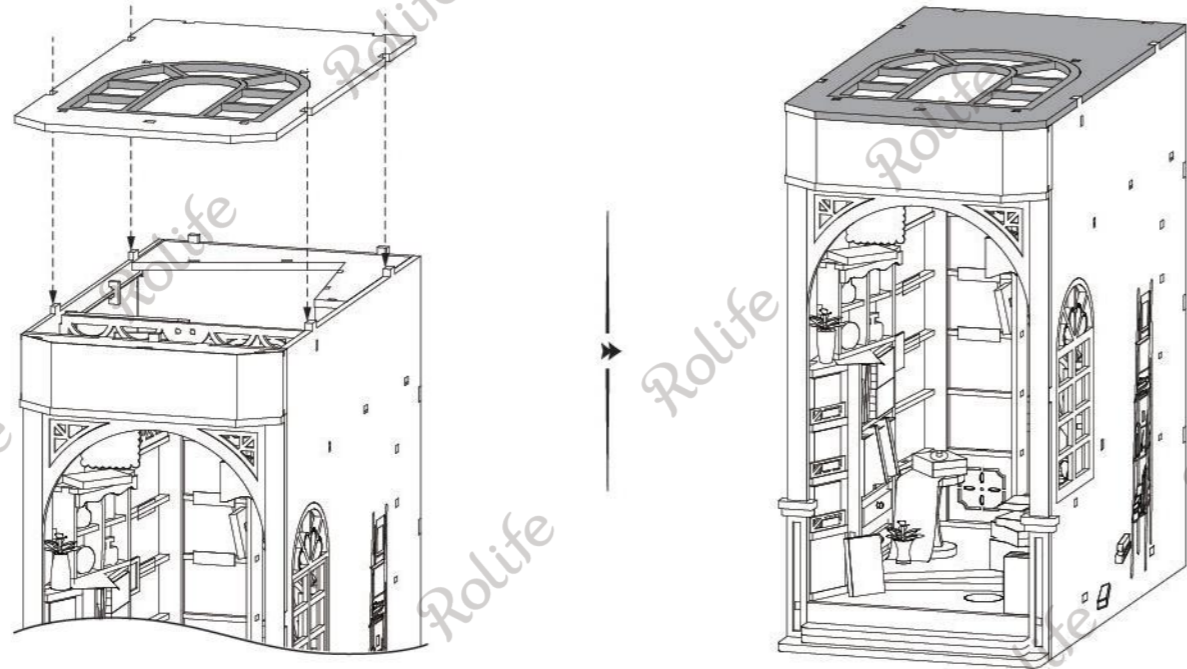
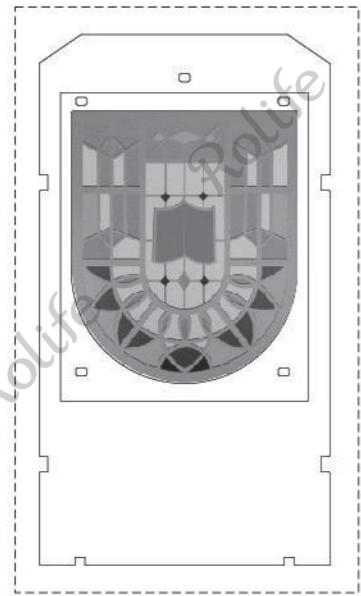

Roll up the paper.
 Rollen Sie das Papier auf.
 Enroulez le papier.
 Arrotolare la carta.
 Enrolle el papel.

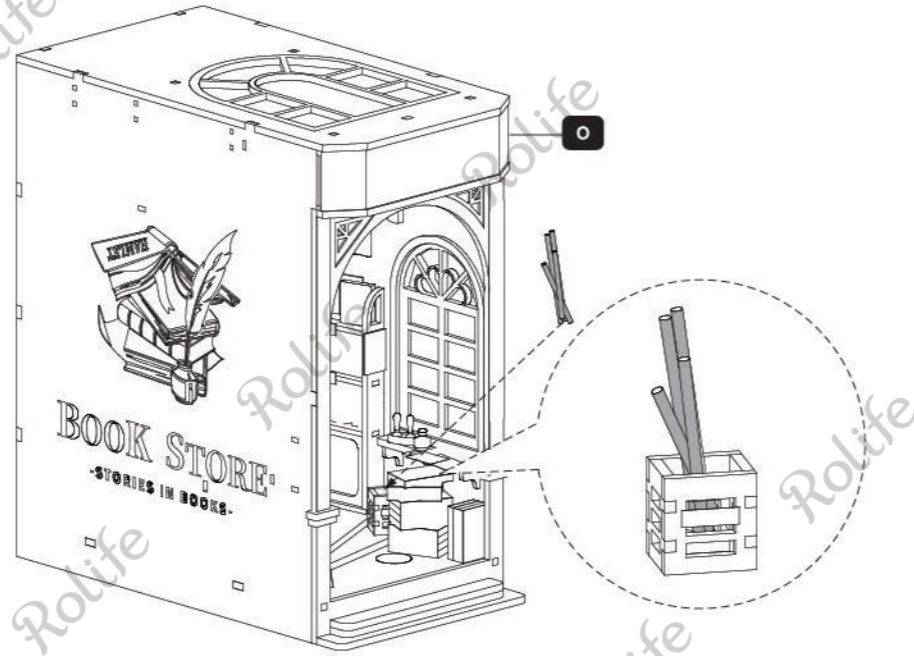

13

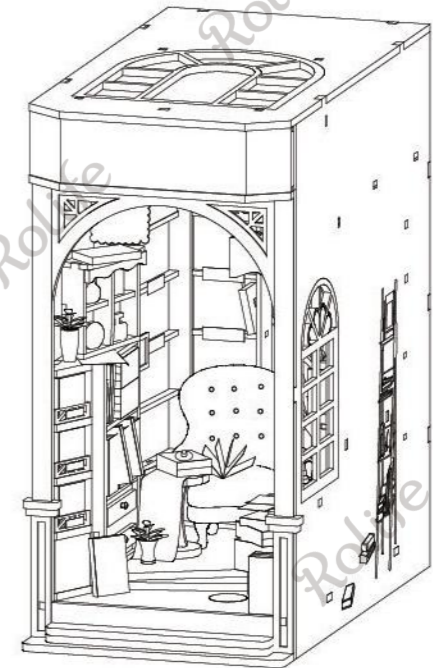
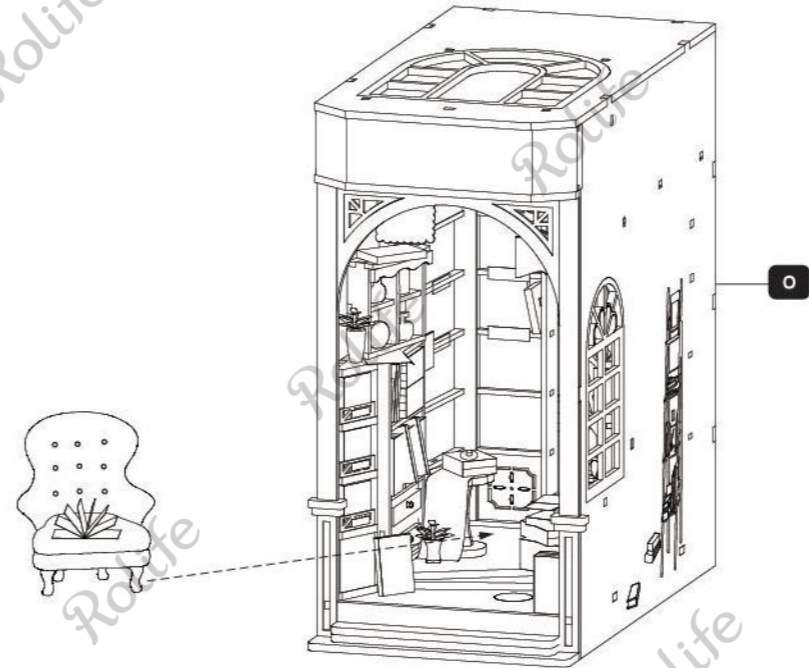
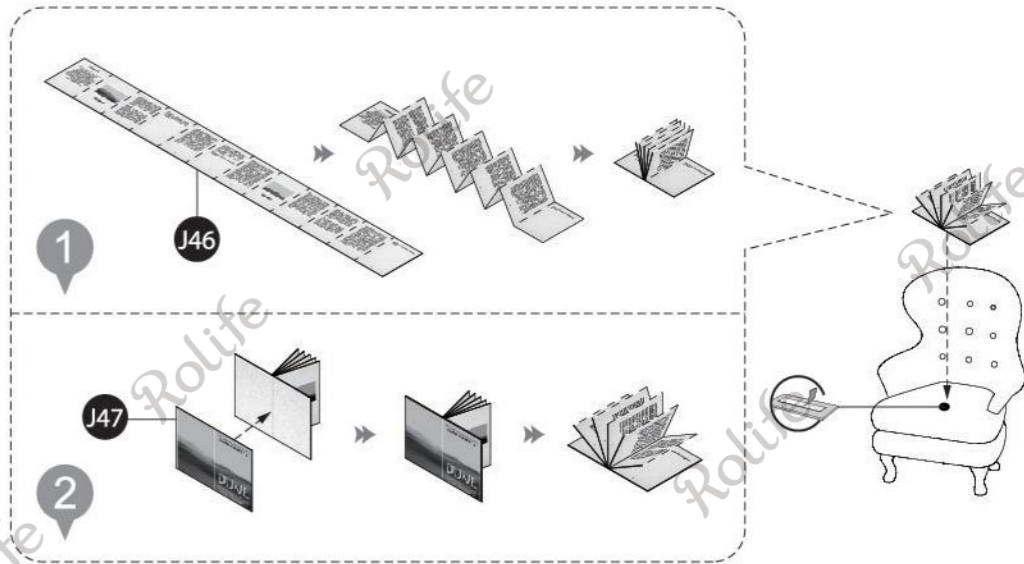
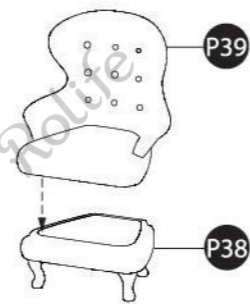

Complete.
 Fertig.
 Terminé.
 Completo.
 Completado.

★ Assembly Instruction
 Anleitung zum Zusammenbau
 Instructions pour l'assemblage
 Istruzioni per il montaggio
 Instrucciones de montaje

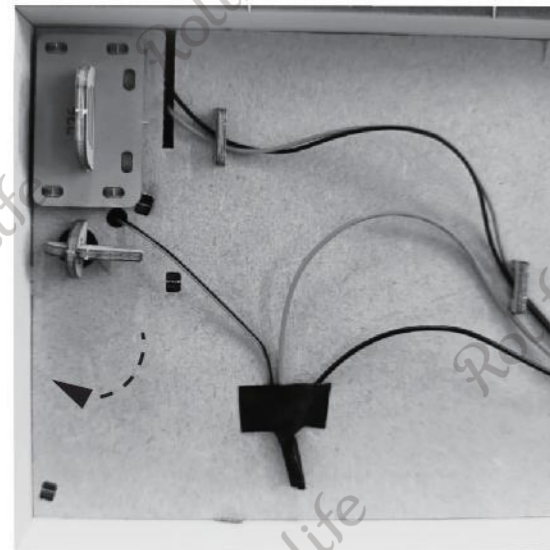

Loosen the screw to replace the battery.
 Lösen Sie die Schraube, um die Batterie auszuwechseln.
 Desserrez la vis pour remplacer la pile.
 Allentare la vite per cambiare la batteria.
 Afloje el tornillo para reemplazar la batería.

Touch here to turn on the light.
 Berühren Sie hier, um das Licht einzuschalten.
 Touchez ici pour allumer la lumière.
 Toccare qui per accendere la luce.
 Toque aquí para encender la luz.



BOOK NOOK & WONDERLAND

BOOK STORE
 • TGB07



ROLIFE Facebook



rolife.robotime.com/



TGB01
Sakura Densya



TGB02
Sunshine Town



TGB03
Magic House



TGB04
Time Travel

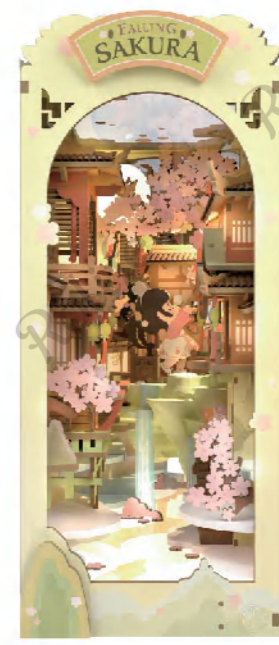

TGB05
Falling Sakura



TGB06
Garden House